

Capitolul 7

Raspunsul in frecventa al circuitelor. Stabilitatea circuitelor cu reactie

7.1. Caracteristicile de frecventa ale functiilor elementare. Diagrame Bode

7.1. Caracteristicile de frecventa ale functiilor elementare. Diagrame Bode

Constanta (A_0)

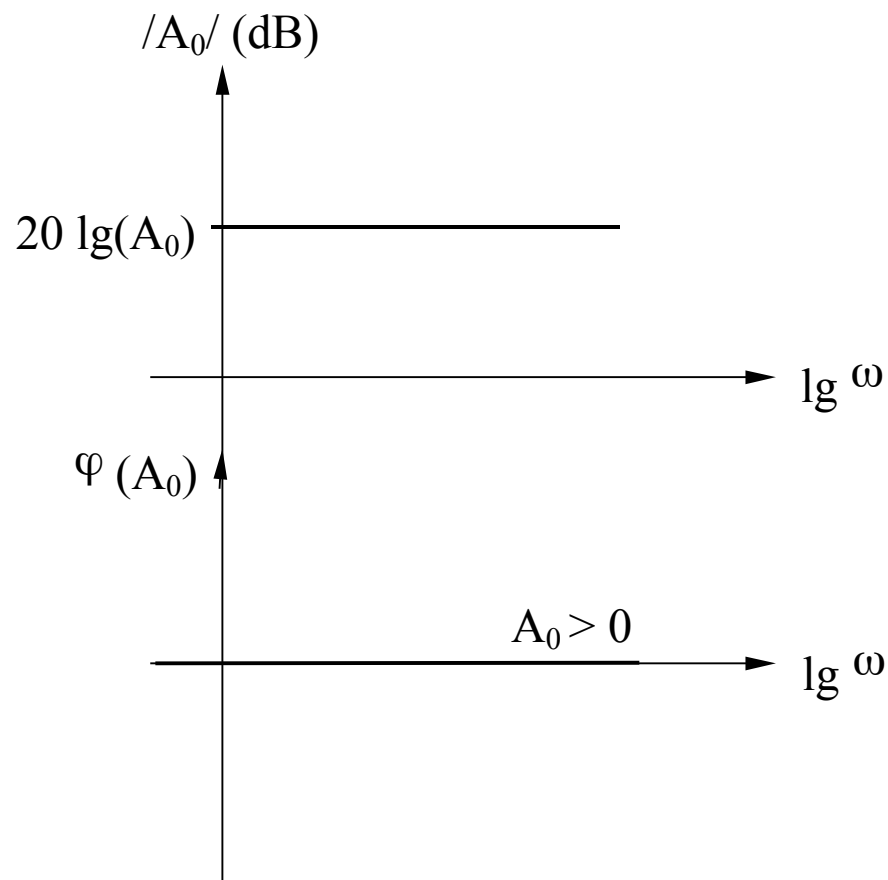

$$A_0 = ct.$$

Zero real negativ (A_1)

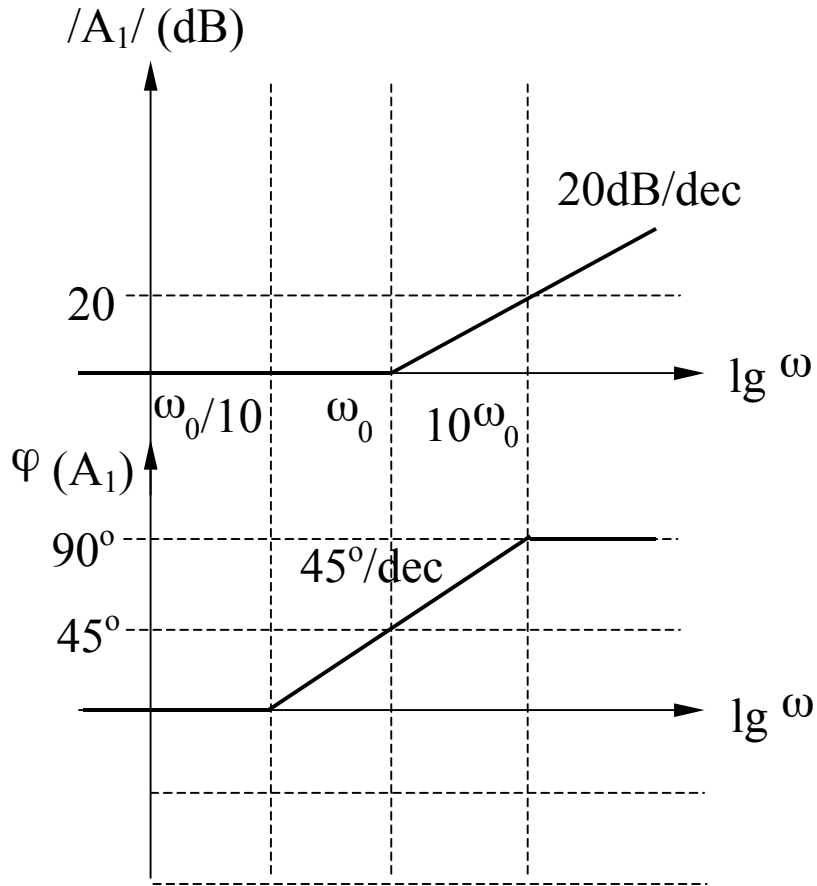

$$A_1 = 1 + j \frac{\omega}{\omega_0}$$

$$|A_1| = 20 \lg \left[\sqrt{1 + \left(\frac{\omega}{\omega_0} \right)^2} \right]$$

$$\varphi(A_1) = \arctg \left(\frac{\omega}{\omega_0} \right)$$

Zero real negativ (A_1) - continuare

Amplitudine

$$|A_1| = 20 \lg \left[\sqrt{1 + \left(\frac{\omega}{\omega_0} \right)^2} \right]$$

$$\omega \ll \omega_0 \Rightarrow |A_1| \rightarrow 0$$

(asimptota joasa frecventa)

$$\omega \gg \omega_0 \Rightarrow |A_1| \rightarrow 20 \lg \left(\frac{\omega}{\omega_0} \right)$$

(asimptota inalta frecventa)

$$\omega = \omega_0 \Rightarrow |A_1| = 20 \lg \sqrt{1+1} = 3dB$$

$$\omega = \frac{\omega_0}{2} \Rightarrow |A_1| = 20 \lg \sqrt{1 + \frac{1}{4}} = 1dB$$

$$\omega = 2\omega_0 \Rightarrow |A_1| = 20 \lg \sqrt{1+4} \cong 7dB$$

$$\Rightarrow \Delta |A_1| = (7 - 6)dB = 1dB$$

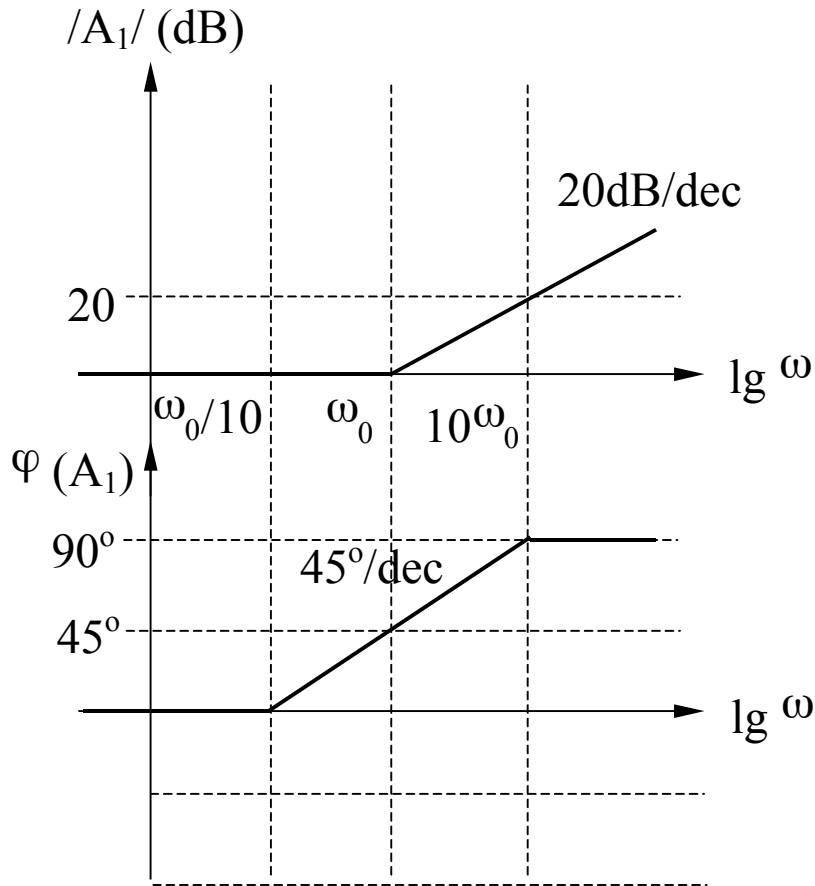

Zero real negativ (A_1) - continuare

Faza

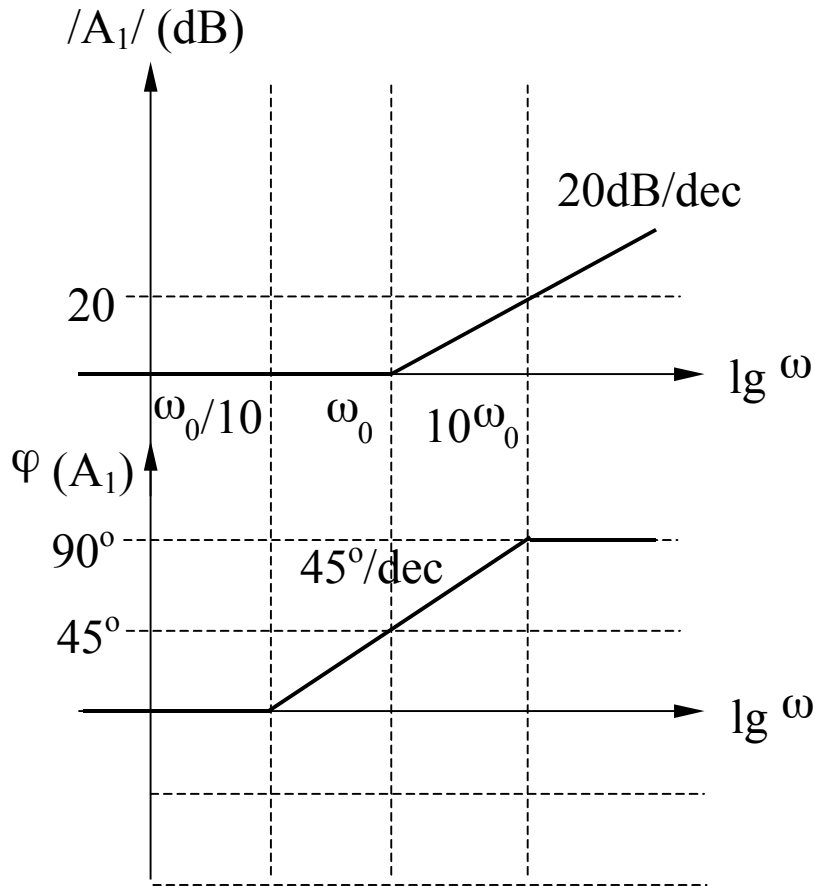

$$\varphi(A_1) = \arctg\left(\frac{\omega}{\omega_0}\right)$$

$$\omega \ll \omega_0 \Rightarrow \varphi(A_1) = \arctg(0) = 0^\circ$$

(asimptota joasa frecventa)

$$\omega \gg \omega_0 \Rightarrow \varphi(A_1) = \arctg(\infty) = 90^\circ$$

(asimptota inalta frecventa)

$$\omega = \omega_0 \Rightarrow \varphi(A_1) = \arctg(1) = 45^\circ$$

$$\omega = 10\omega_0 \Rightarrow \varphi(A_3) = \arctg(10) \cong 84^\circ$$

(eroare 6°)

$$\omega = \omega_0 / 10 \Rightarrow \varphi(A_3) = \arctg(0,1) \cong 6^\circ$$

(eroare 6°)

Zero real pozitiv (A_2)

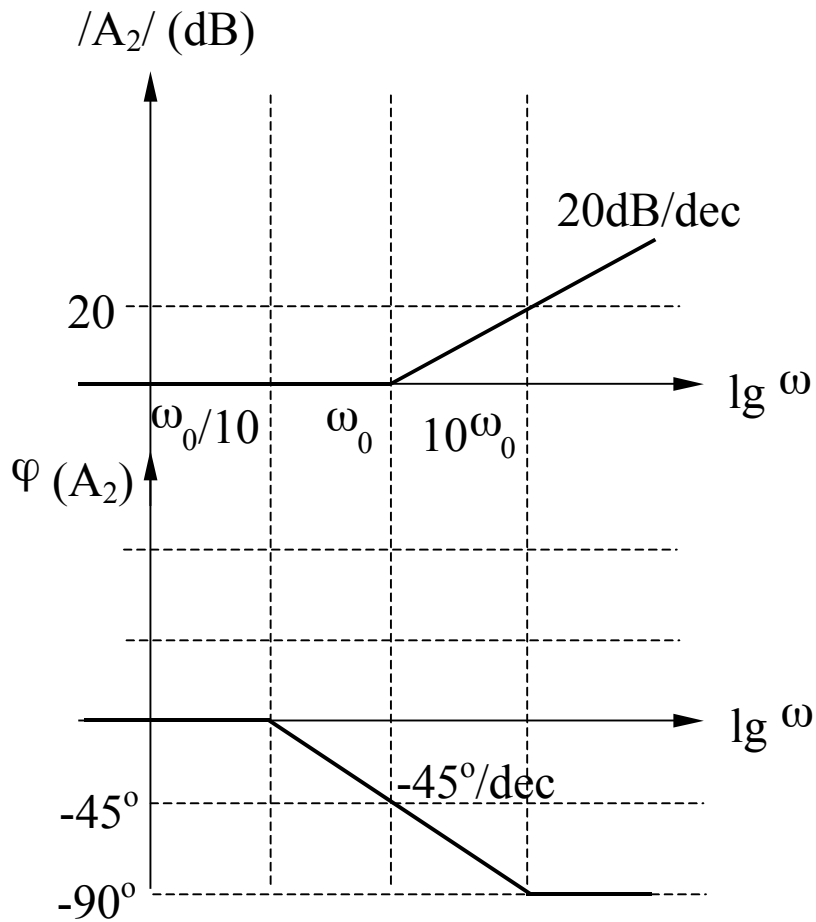

$$A_2 = 1 - j \frac{\omega}{\omega_0}$$

$$|A_2| = 20 \lg \left[\sqrt{1 + \left(\frac{\omega}{\omega_0} \right)^2} \right]$$

$$\varphi(A_2) = -\text{arctg} \left(\frac{\omega}{\omega_0} \right)$$

Pol real negativ (A_3)

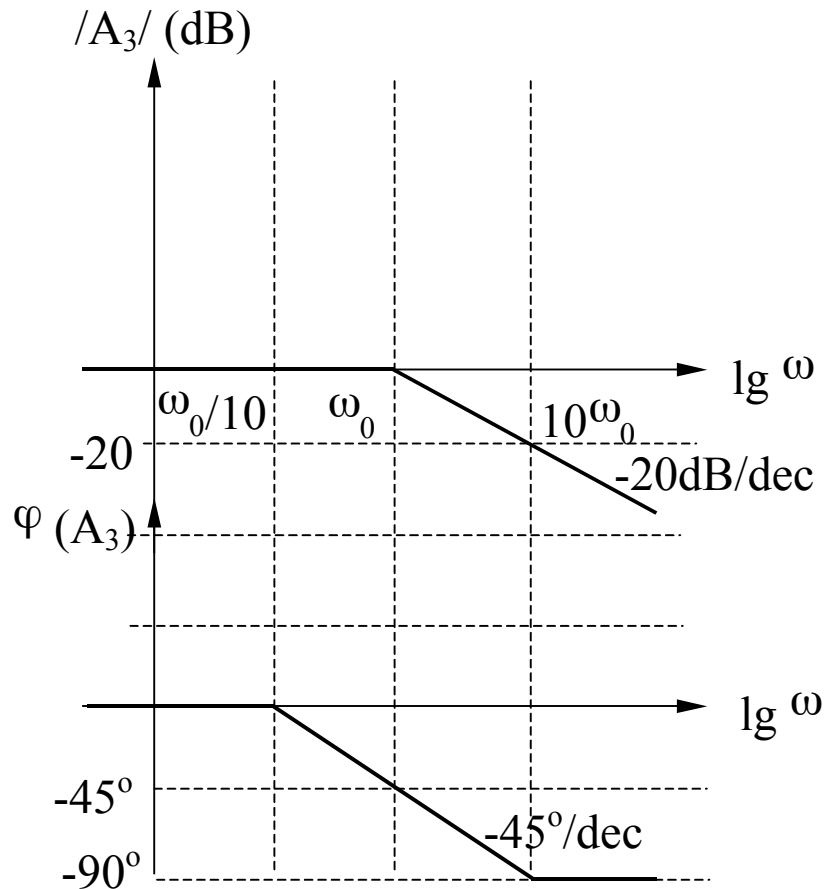

$$A_3 = \frac{1}{1 + j \frac{\omega}{\omega_0}}$$

$$|A_3| = -20 \lg \left[\sqrt{1 + \left(\frac{\omega}{\omega_0} \right)^2} \right]$$

$$\varphi(A_3) = -\arctg \left(\frac{\omega}{\omega_0} \right)$$

Pol real negativ (A_3) - continuare

Amplitudine

$$|A_3| = -20 \lg \left[\sqrt{1 + \left(\frac{\omega}{\omega_0} \right)^2} \right]$$

$$\omega \ll \omega_0 \Rightarrow |A_3| \rightarrow 0$$

(asimptota joasa frecventa)

$$\omega \gg \omega_0 \Rightarrow |A_3| \rightarrow -20 \lg \left(\frac{\omega}{\omega_0} \right)$$

(asimptota inalta frecventa)

$$\omega = \omega_0 \Rightarrow |A_3| = -20 \lg \sqrt{1+1} = -3dB$$

$$\omega = \frac{\omega_0}{2} \Rightarrow |A_3| = -20 \lg \sqrt{1 + \frac{1}{4}} = -1dB$$

$$\omega = 2\omega_0 \Rightarrow |A_3| = -20 \lg \sqrt{1+4} \cong -7dB$$

$$\Rightarrow \Delta |A_3| = ((-7) - (-6))dB = -1dB$$

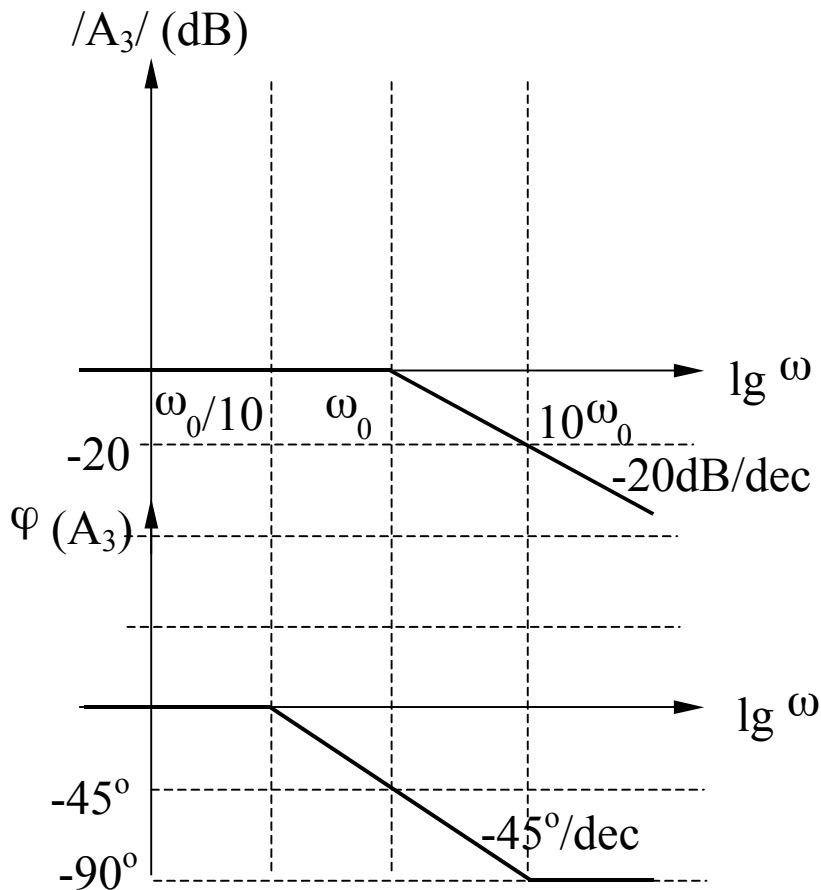

Pol real negativ (A_3) - continuare

Faza

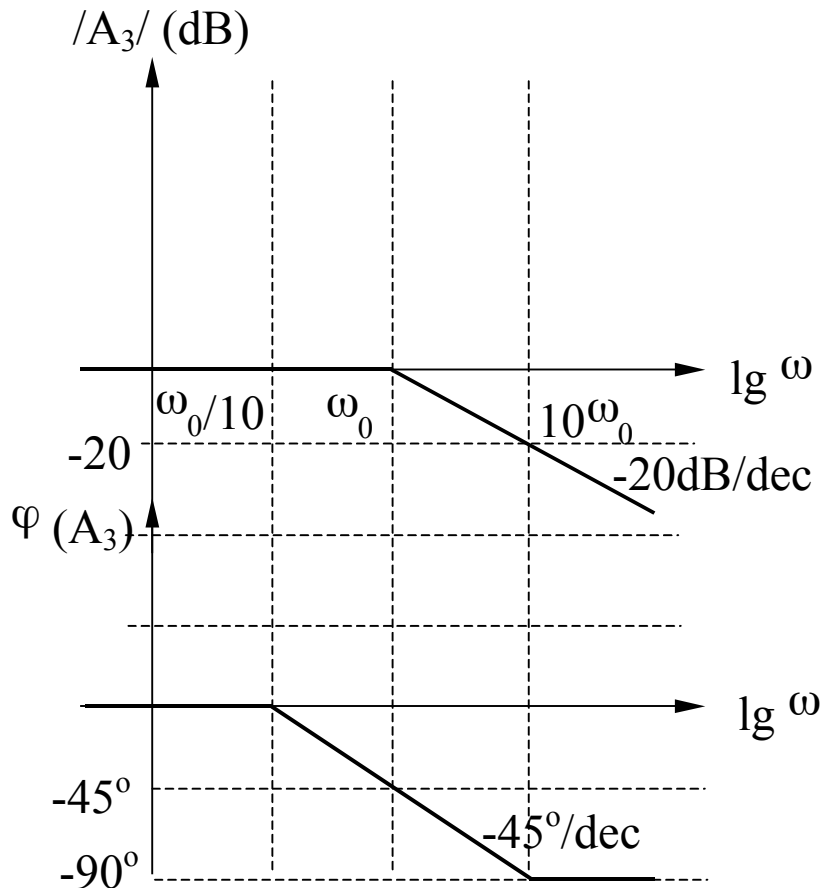

$$\varphi(A_3) = -\arctg\left(\frac{\omega}{\omega_0}\right)$$

$$\omega \ll \omega_0 \Rightarrow \varphi(A_3) = -\arctg(0) = 0^\circ$$

(asimptota joasa frecventa)

$$\omega \gg \omega_0 \Rightarrow \varphi(A_3) = -\arctg(\infty) = -90^\circ$$

(asimptota inalta frecventa)

$$\omega = \omega_0 \Rightarrow \varphi(A_3) = -\arctg(1) = -45^\circ$$

$$\omega = 10\omega_0 \Rightarrow \varphi(A_3) = -\arctg(10) \cong -84^\circ$$

(eroare 6°)

$$\omega = \omega_0 / 10 \Rightarrow \varphi(A_3) = -\arctg(0,1) \cong -6^\circ$$

(eroare 6°)

Zero simplu in origine (A_4)

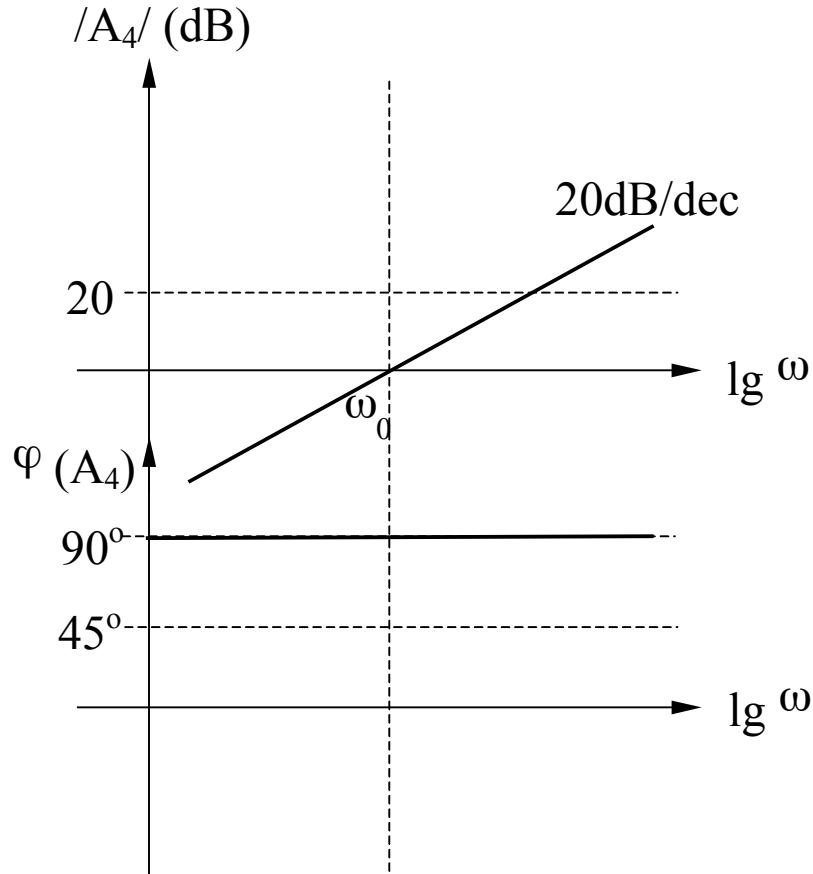

$$A_4 = j \frac{\omega}{\omega_0}$$

$$|A_4| = 20 \lg \left(\frac{\omega}{\omega_0} \right)$$

$$\varphi(A_4) = 90^\circ$$

Pol simplu in origine (A_5)

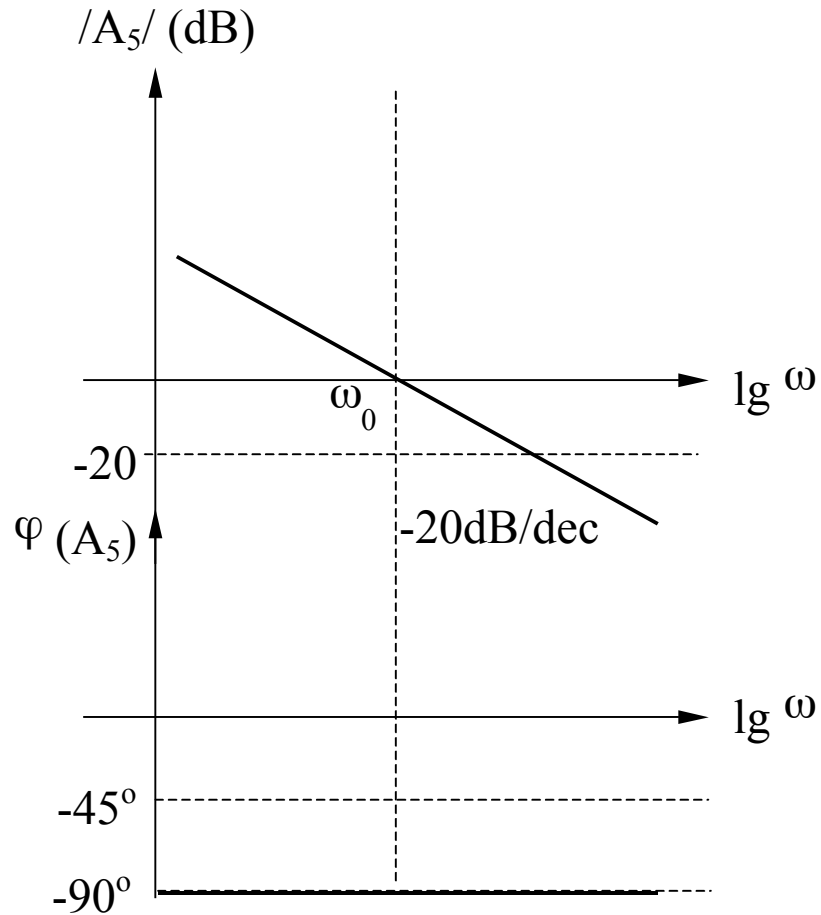

$$A_5 = \frac{1}{j \frac{\omega}{\omega_0}}$$

$$|A_5| = -20 \lg \left(\frac{\omega}{\omega_0} \right)$$

$$\varphi(A_5) = -90^\circ$$

Zero multiplu in origine (A_6)

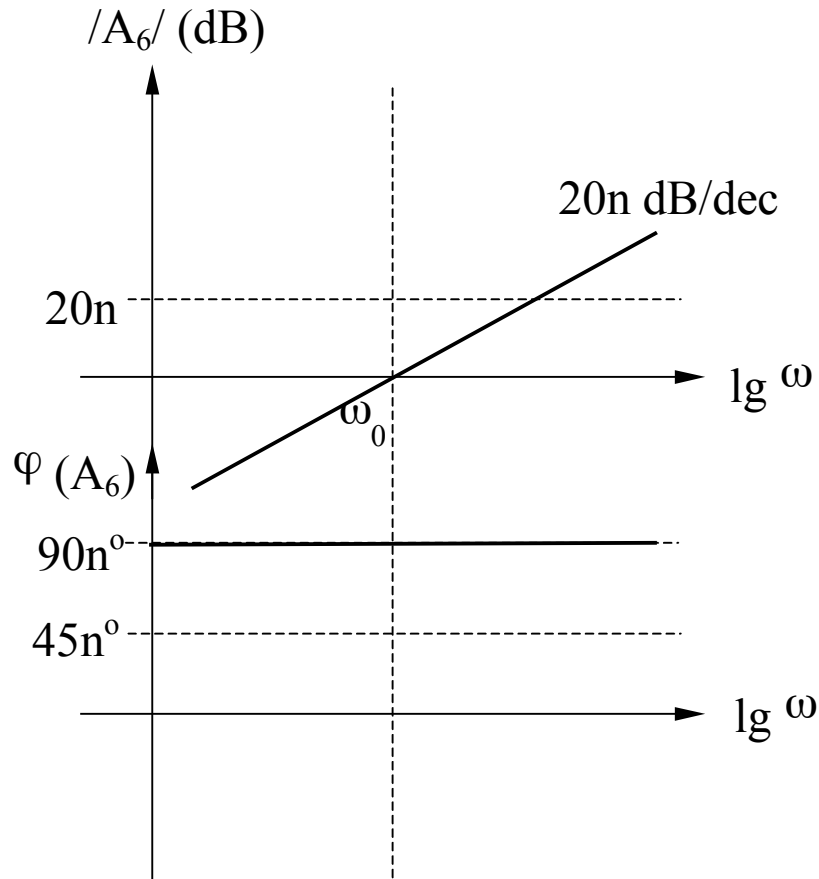

$$A_6 = \left(j \frac{\omega}{\omega_0} \right)^n$$

$$|A_6| = 20 \times n \lg \left(\frac{\omega}{\omega_0} \right)$$

$$\varphi(A_6) = n \times 90^\circ$$

Pol multiplu in origine (A_7)

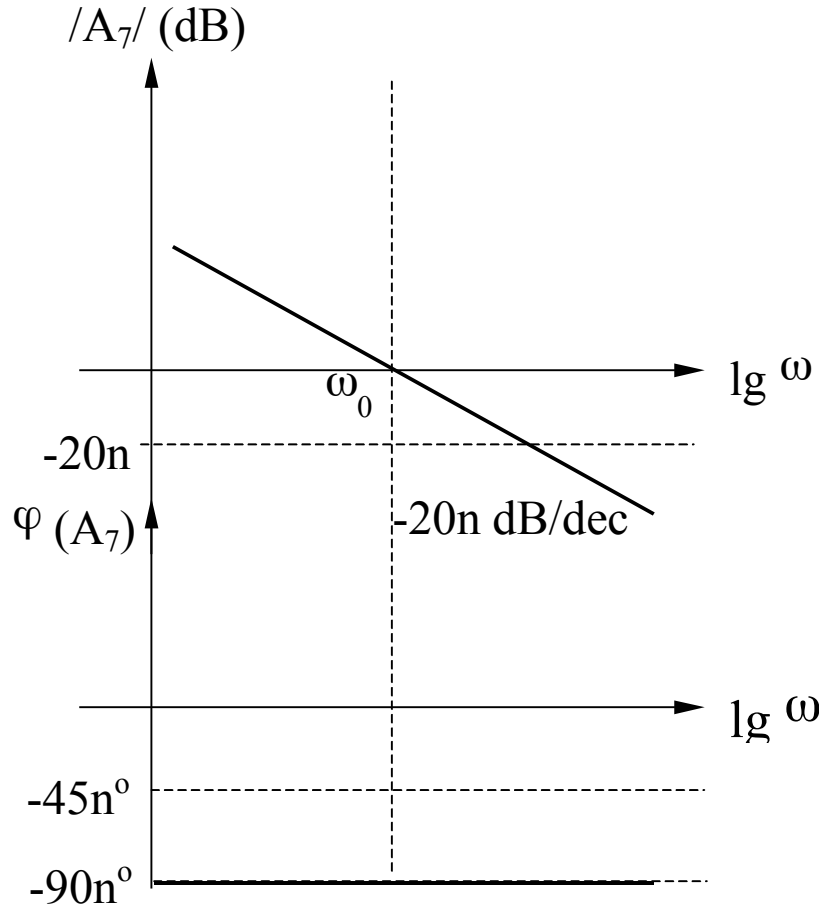

$$A_7 = \frac{1}{\left(j \frac{\omega}{\omega_0}\right)^n}$$

$$|A_7| = -20 \times n \lg \left(\frac{\omega}{\omega_0} \right)$$

$$\varphi(A_7) = -n \times 90^\circ$$

Zero real negativ multiplu (A_8)

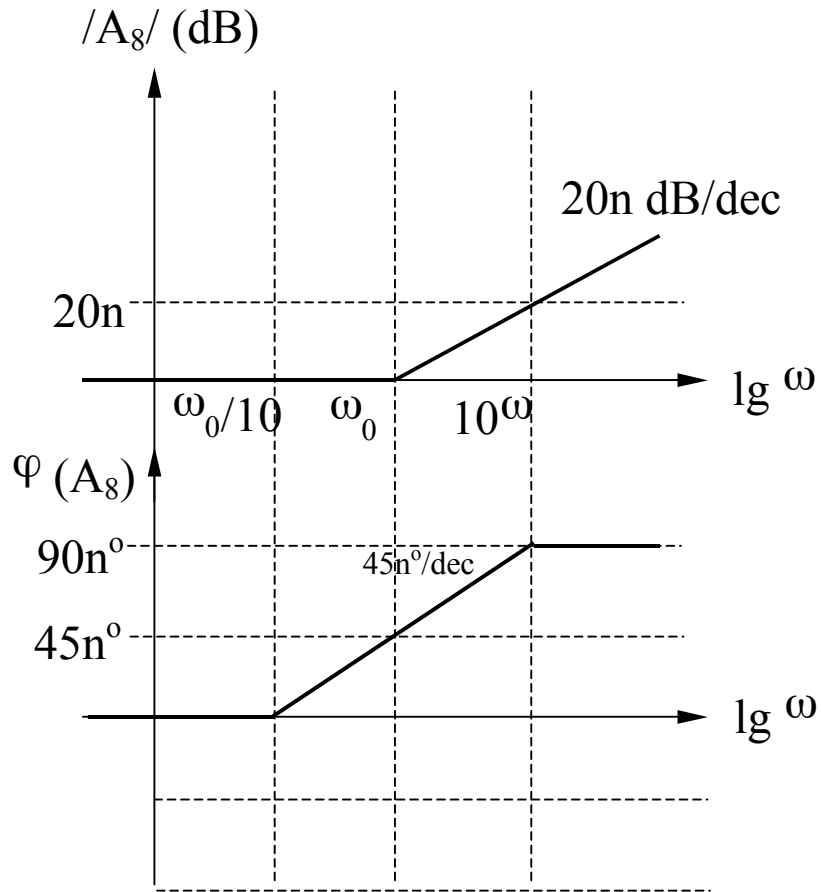

$$A_8 = \left(1 + j \frac{\omega}{\omega_0}\right)^n$$

$$|A_8| = 20 \times n \lg \left[\sqrt{1 + \left(\frac{\omega}{\omega_0}\right)^2} \right]$$

$$\omega \ll \omega_0 \Rightarrow |A_8| \rightarrow 0$$

$$\omega \gg \omega_0 \Rightarrow |A_8| \rightarrow 20 \times n \lg \left(\frac{\omega}{\omega_0} \right)$$

$$\varphi(A_8) = n \times \arctg \left(\frac{\omega}{\omega_0} \right)$$

Pol real negativ multiplu (A_9)

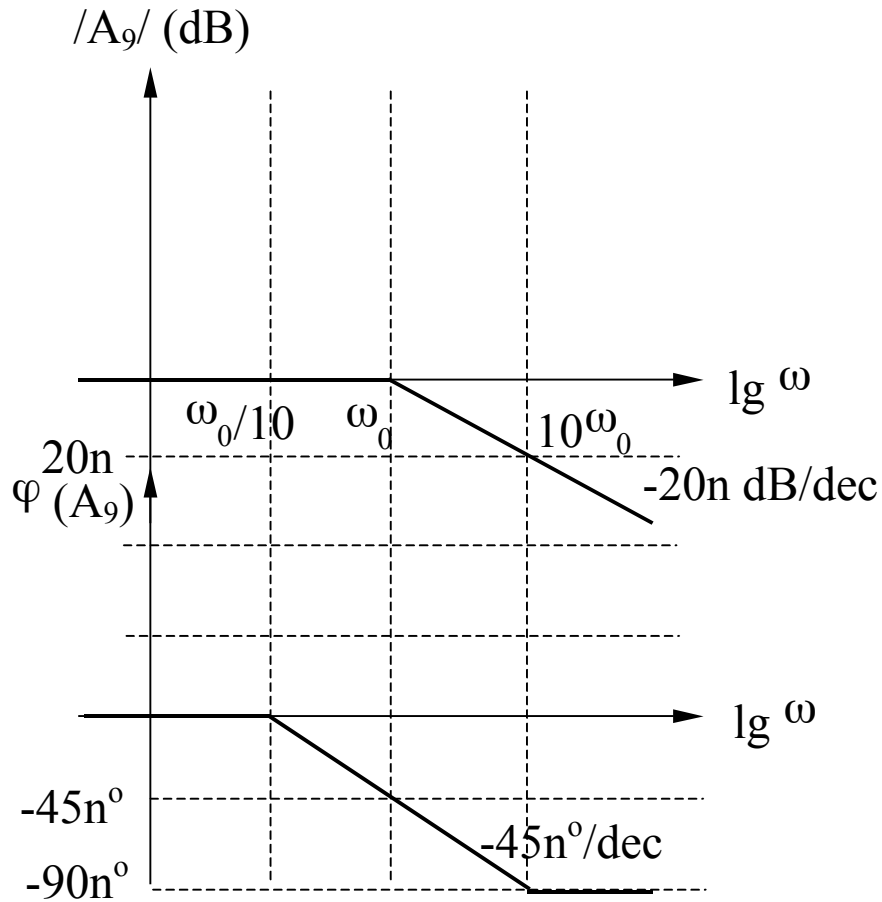

$$A_9 = \frac{1}{\left(1 + j \frac{\omega}{\omega_0}\right)^n}$$

$$|A_9| = -20 \times n \lg \left[\sqrt{1 + \left(\frac{\omega}{\omega_0}\right)^2} \right]$$

$$\omega \ll \omega_0 \Rightarrow |A_9| \rightarrow 0$$

$$\omega \gg \omega_0 \Rightarrow |A_9| \rightarrow -20 \times n \lg \left(\frac{\omega}{\omega_0} \right)$$

$$\varphi(A_9) = -n \times \arctg \left(\frac{\omega}{\omega_0} \right)$$

Factor quadratic (A_{10})

$$A_{10}(s) = \frac{1}{s^2 + 2\xi\omega_0 s + \omega_0^2} = \frac{1}{s^2 + \frac{\omega_0}{Q}s + \omega_0^2}$$

ω_0 = frecventa de rezonanta

ξ = factor de amortizare

Q = factor de calitate

$$\xi Q = \frac{1}{2}$$

Determinarea polilor: din ecuatia caracteristica:

$$s^2 + 2\xi\omega_0 s + \omega_0^2 = s^2 + \frac{\omega_0}{Q}s + \omega_0^2 = 0$$

Rezulta:

$$p_{1,2} = -\xi\omega_0 \pm j\omega_0\sqrt{1 - \xi^2}$$

$$p_{1,2} = -\frac{\omega_0}{2Q} \pm j\omega_0\sqrt{1 - \frac{1}{4Q^2}}$$

Factor quadratic (A_{10}) - continuare

$$p_{1,2} = -\xi\omega_0 \pm j\omega_0\sqrt{1-\xi^2}$$

$$p_{1,2} = -\frac{\omega_0}{2Q} \pm j\omega_0\sqrt{1-\frac{1}{4Q^2}}$$

Situatii posibile:

1. $Q < 0,5$ ($\xi > 1$) \Rightarrow 2 poli reali negativi
2. $Q = 0,5$ ($\xi = 1$) \Rightarrow pol dublu
3. $Q > 0,5$ ($\xi < 1$) \Rightarrow 2 poli complex conjugati
4. $Q \rightarrow \infty$ ($\xi \rightarrow 0$) \Rightarrow 2 poli imaginari

- situatii deja analizate

Factor quadratic (A_{10}) – poli complex conjugati ($Q > 0,5$)

$$p_{1,2} = -\xi\omega_0 \pm j\omega_0\sqrt{1-\xi^2}$$

$$p_{1,2} = -\frac{\omega_0}{2Q} \pm j\omega_0\sqrt{1-\frac{1}{4Q^2}}$$

$$Re(p_1, p_2) = -\xi\omega_0 = -\frac{\omega_0}{2Q}$$

$$Im(p_1, p_2) = \pm\omega_0\sqrt{1-\xi^2} = \pm\omega_0\sqrt{1-\frac{1}{4Q^2}}$$

$$|p_1, p_2| = \omega_0$$

$$\varphi(p_1, p_2) = \arctg \frac{Im(p_1, p_2)}{Re(p_1, p_2)} = \pm \arctg \sqrt{\frac{1}{\xi^2} - 1} = \pm \arctg \sqrt{4Q^2 - 1}$$

Factor quadratic (A_{10}) – poli complex conjugati ($Q > 0,5$)

Caracteristica de frecventa

$$A_{10}(s) = \frac{1}{s^2 + 2\xi\omega_0 s + \omega_0^2} = \frac{1}{s^2 + \frac{\omega_0}{Q}s + \omega_0^2}$$

$$F(j\omega) = \omega_0^2 A_{10}(j\omega) = \frac{1}{1 + 2j\xi \frac{\omega}{\omega_0} + \left(j \frac{\omega}{\omega_0}\right)^2} = \frac{1}{1 + \frac{j}{Q} \frac{\omega}{\omega_0} + \left(j \frac{\omega}{\omega_0}\right)^2}$$

Se noteaza: $u = \omega / \omega_0$; $x = (\omega / \omega_0)^2$. Rezulta:

$$F(ju) = \frac{1}{1 + 2j\xi u - u^2} = \frac{1}{1 + \frac{j}{Q} u - u^2}$$

$$|F(ju)| = \frac{1}{\sqrt{(1 - u^2)^2 + 4\xi^2 u^2}}; \quad |F(jx)| = \frac{1}{\sqrt{(1 - x)^2 + 4\xi^2 x}}$$

$$\varphi(ju) = -\operatorname{arctg} \frac{2\xi u}{1 - u^2}$$

Factor quadratic (A_{10}) – poli complex conjugati ($Q > 0,5$)

Caracteristica de frecventa (continuare)

$$|F(ju)|_{dB} = -20 \lg \sqrt{(1-u^2)^2 + 4\xi^2 u^2}; \quad |F(jx)|_{dB} = -20 \lg \sqrt{(1-x)^2 + 4\xi^2 x}$$

Se noteaza: $f(x) = (1-x)^2 + 4\xi^2 x = 1 + (4\xi^2 - 2)x + x^2$

Conditia de minim a functiei $f(x)$ se obtine prin anularea derivatei acesteia:

$$f'(x) = (4\xi^2 - 2) + 2x = 0 \Rightarrow x = 1 - 2\xi^2 > 0 \Rightarrow \xi < \frac{1}{\sqrt{2}} \cong 0,707$$

$$f''(x) = 2 > 0$$

Deci, functia $f(x)$ va avea un minim pentru $x = 1 - 2\xi^2$ (echivalent cu **existenta unui maxim al $|F(jx)|_{dB}$) numai daca $\xi < 0,707$ (sau $Q > 0,707$).**

Se va obtine un maxim pentru ω_p avand expresia:

$$x = 1 - 2\xi^2 \Leftrightarrow \omega_{Peak} = \omega_P = \omega_0 \sqrt{1 - 2\xi^2} = \omega_0 \sqrt{1 - \frac{1}{2Q^2}}$$

Factor quadratic (A_{10}) – poli complex conjugati ($Q > 0,5$)

Caracteristica de frecventa (continuare)

Valoarea acestui maxim este:

$$|F(jx)|_{dB} = -20 \lg \sqrt{(1 - 1 + 2\xi^2)^2 + 4\xi^2(1 - 2\xi^2)}$$

$$|F(jx)|_{dB} = 20 \lg \frac{1}{2\xi\sqrt{1-\xi^2}} = 20 \lg \frac{Q}{\sqrt{1-\frac{1}{4Q^2}}}$$

Factor quadratic (A_{10}) – poli complex conjugati ($Q > 0,5$)

Caracteristica de frecventa (continuare)

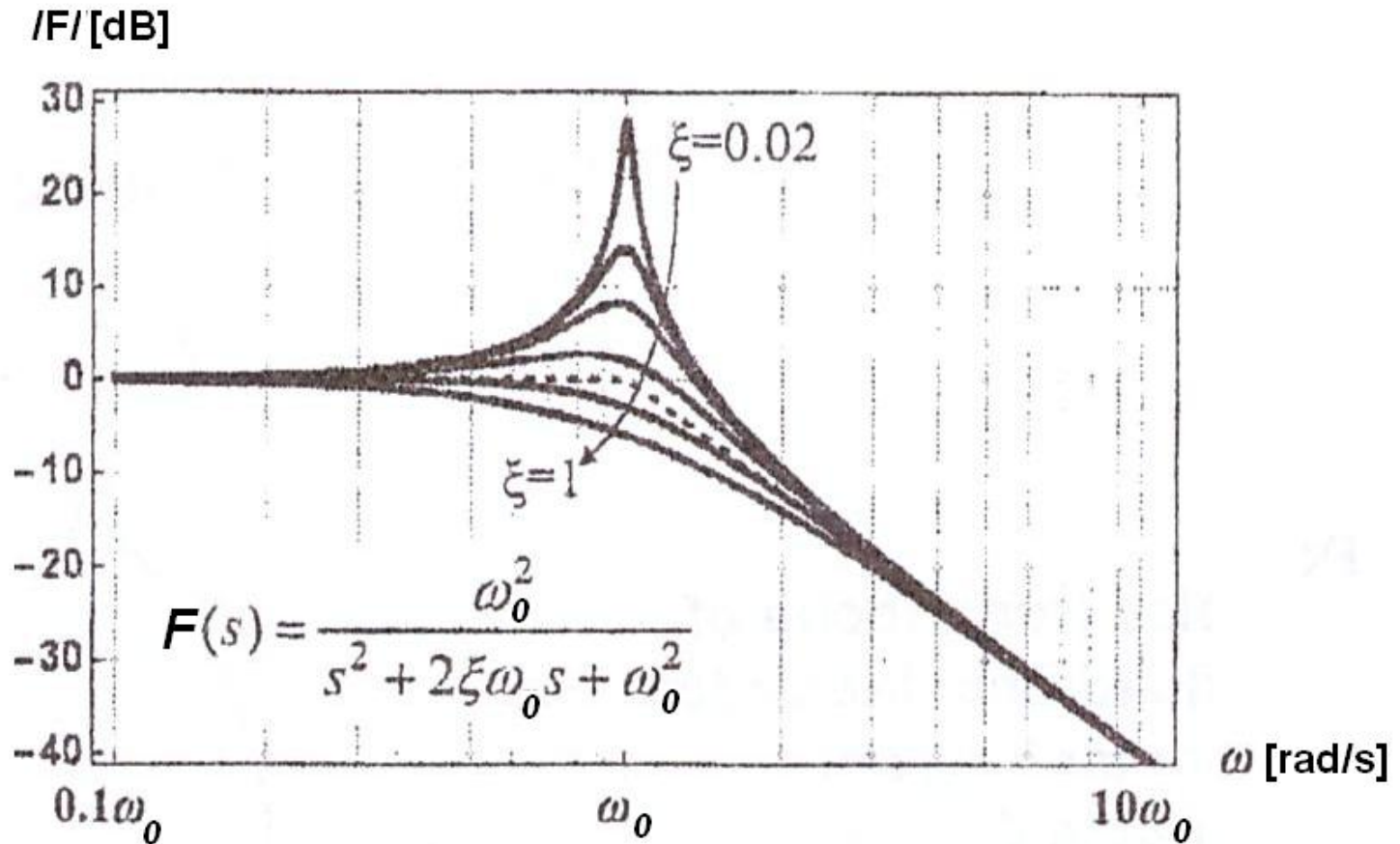

Factor quadratic (A_{10}) – poli complex conjugati ($Q > 0,5$)

Caracteristica de frecventa (continuare)

faza [grade]

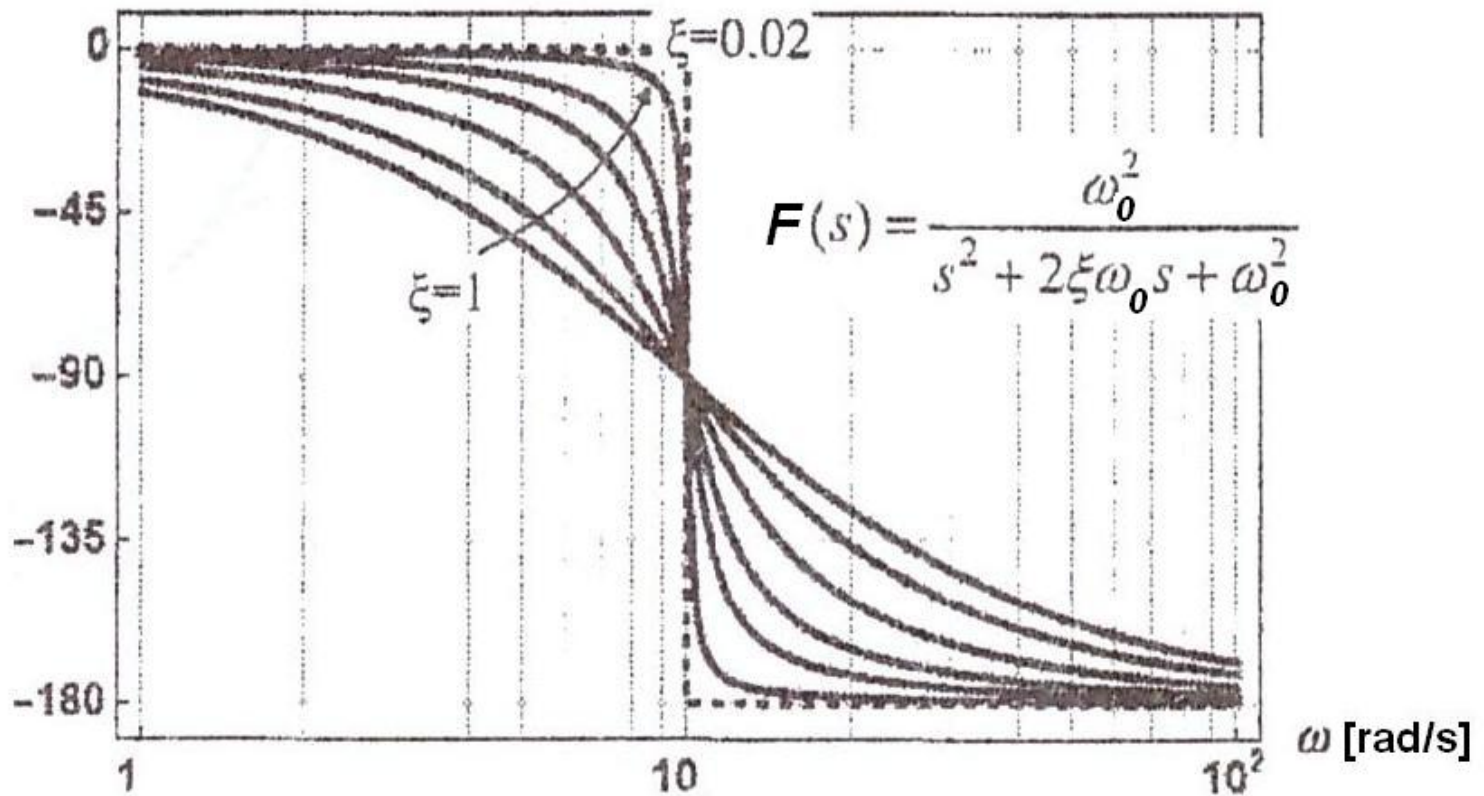

Factor quadratic (A_{10}) – poli complex conjugati ($Q > 0,5$)

Trasarea diagramelor Bode (MODUL) pentru polii complex conjugati

$$|F(ju)|_{dB} = -20 \lg \sqrt{(1 - u^2)^2 + 4\xi^2 u^2}$$

$$|F(j\omega)|_{dB} = -20 \lg \sqrt{\left[1 - \left(\frac{\omega}{\omega_0}\right)^2\right]^2 + 4\xi^2 \left(\frac{\omega}{\omega_0}\right)^2}$$

$$\omega \ll \omega_0 \Rightarrow |F(j\omega)|_{dB} \rightarrow 0dB \quad (\text{asimptota joasa frecventa})$$

$$\omega \gg \omega_0 \Rightarrow |F(j\omega)|_{dB} \cong -40 \lg \left(\frac{\omega}{\omega_0}\right) \quad (\text{asimptota inalta frecventa})$$

$$\omega = \omega_0 \Rightarrow |F(j\omega)|_{dB} = -20 \lg(2\xi)$$

Factor quadratic (A_{10}) – poli complex conjugati ($Q > 0,5$)

**Trasarea diagramelor Bode (MODUL) pentru polii complex conjugati (continuare)
(daca EXISTA maxim: $0 < \xi < 0,707$ sau $Q > 0,707$)**

1. Se traseaza asimptotele:

- la JF: 0dB pana in ω_0

- la IF: o dreapta cu panta de -40dB/decada pornind din ω_0

2. Se calculeaza $\omega = \omega_p$ pentru care se obtine maximul:

$$\omega_p = \omega_0 \sqrt{1 - 2\xi^2} = \omega_0 \sqrt{1 - \frac{1}{2Q^2}}$$

3. Se calculeaza valoarea maximului:

$$|F_P|_{dB} = 20 \lg \frac{1}{2\xi \sqrt{1 - \xi^2}} = 20 \lg \frac{Q}{\sqrt{1 - \frac{1}{4Q^2}}}$$

4. Se traseaza o curba care tinde asimptotic catre cele 2 axe (JF si IF) si care trece prin punctul de maxim ($\omega_p, /F_P/dB$)

Factor quadratic (A_{10}) – poli complex conjugati ($Q > 0,5$)

**Trasarea diagramelor Bode (MODUL) pentru polii complex conjugati (continuare)
(daca NU EXISTA maxim: $\xi > 0,707$ sau $Q < 0,707$)**

1. Se traseaza asimptotele:

- la JF: 0dB pana in ω_0

- la IF: o dreapta cu panta de -40dB/decada pornind din ω_0

2. Se traseaza o curba care tinde asimptotic catre cele 2 axe (JF si IF)

Factor quadratic (A_{10}) – poli complex conjugati ($Q > 0,5$)

Trasarea diagramelor Bode (FAZA) pentru poli complex conjugati

$$\varphi(ju) = -\operatorname{arctg} \frac{2\xi u}{1-u^2} = -\operatorname{arctg} \frac{\frac{1}{Q}u}{1-u^2}$$

$$\varphi(j\omega) = -\operatorname{arctg} \frac{2\xi \frac{\omega}{\omega_0}}{1-\left(\frac{\omega}{\omega_0}\right)^2} = -\operatorname{arctg} \frac{\frac{1}{Q} \frac{\omega}{\omega_0}}{1-\left(\frac{\omega}{\omega_0}\right)^2}$$

$$\omega \ll \omega_0 \Rightarrow \varphi \rightarrow -\operatorname{arctg} 0 = 0 \quad (\text{asimptota joasa frecventa})$$

$$\omega \gg \omega_0 \Rightarrow \varphi \rightarrow -\operatorname{arctg} \infty = -180^\circ \quad (\text{asimptota inalta frecventa})$$

$$\omega = \omega_0 \Rightarrow \varphi = \operatorname{arctg}(\infty) = -90^\circ$$

Exemplul 1

$$A(j\omega) = 10^4 \frac{1 + j \frac{\omega}{10^2}}{\left(1 + j \frac{\omega}{10}\right) \left(1 + j \frac{\omega}{10^4}\right)}$$

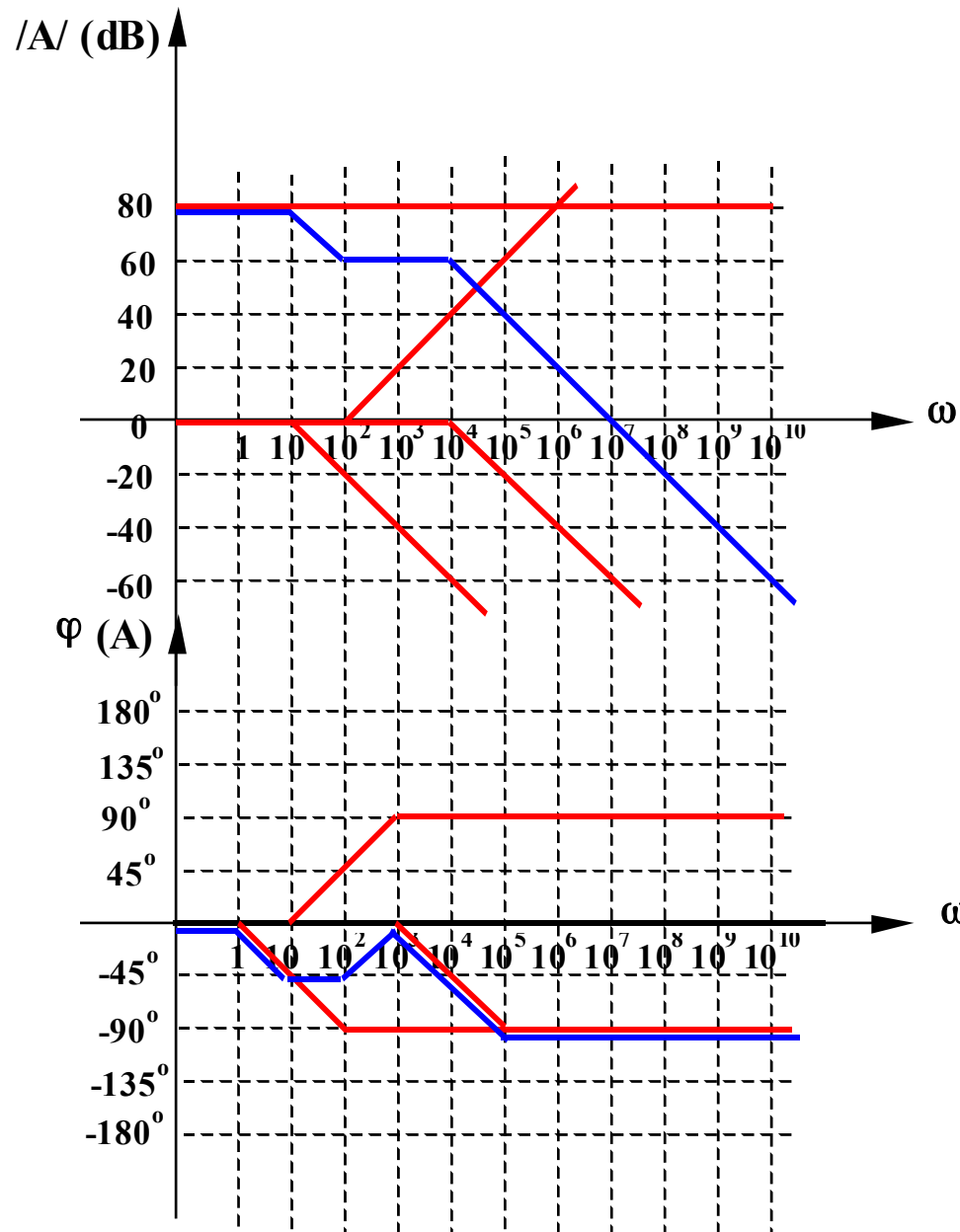

Exemplul 2

$$A(j\omega) = 10^3 \frac{1 + j \frac{\omega}{10^4}}{\left(1 + j \frac{\omega}{10}\right) \left(1 + j \frac{\omega}{10^3}\right)}$$

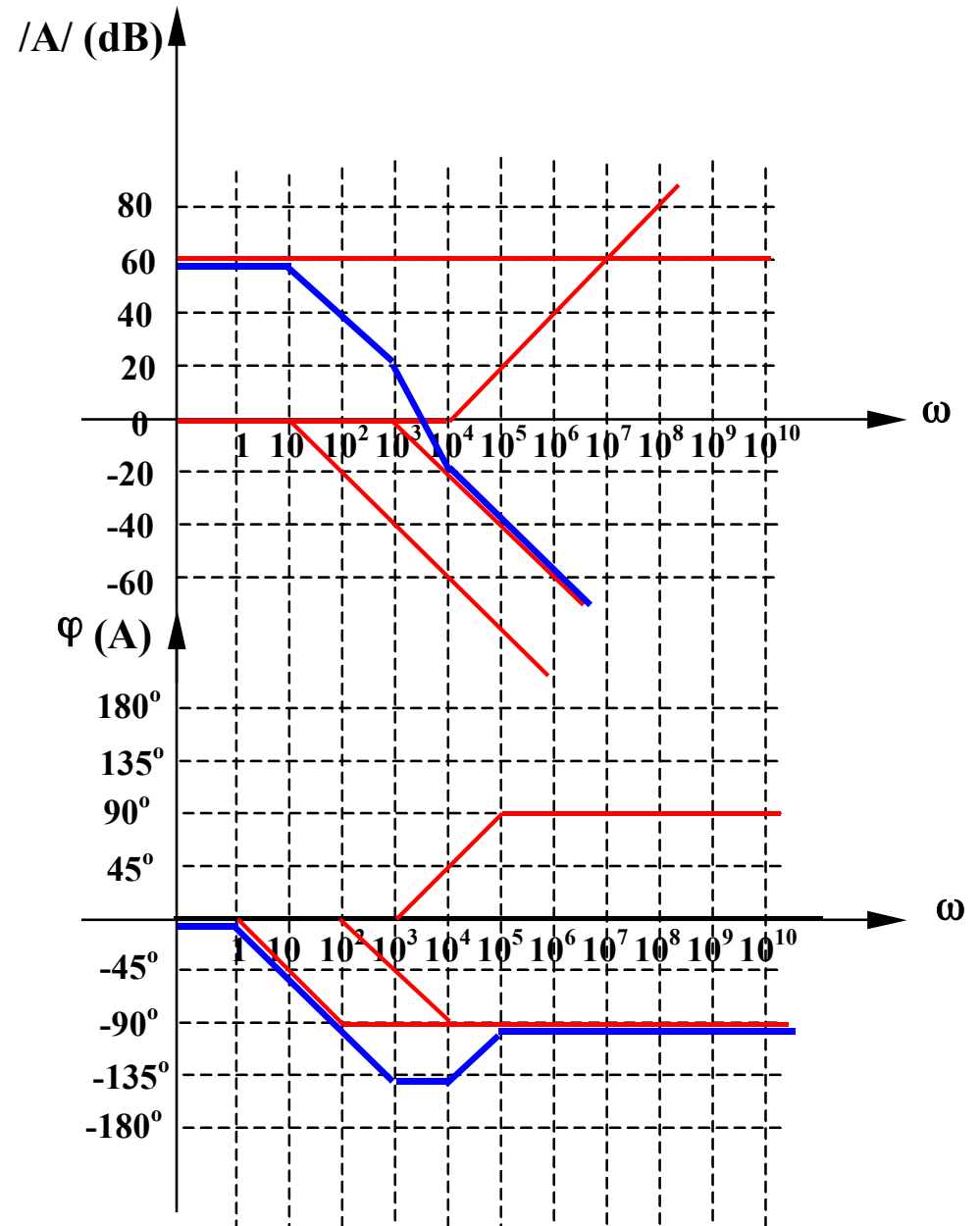

Exemplul 3

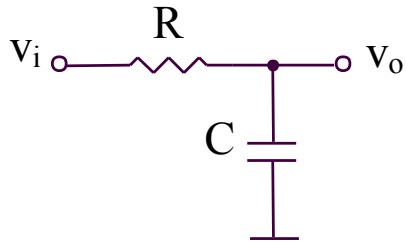

$$RC = 10^{-3} \text{ s}$$

$$\begin{aligned} H(j\omega) &= \frac{v_o}{v_i} = \frac{1/j\omega C}{R + 1/j\omega C} = \\ &= \frac{1}{1 + j\omega RC} = \frac{1}{1 + j\frac{\omega}{10^3}} \end{aligned}$$

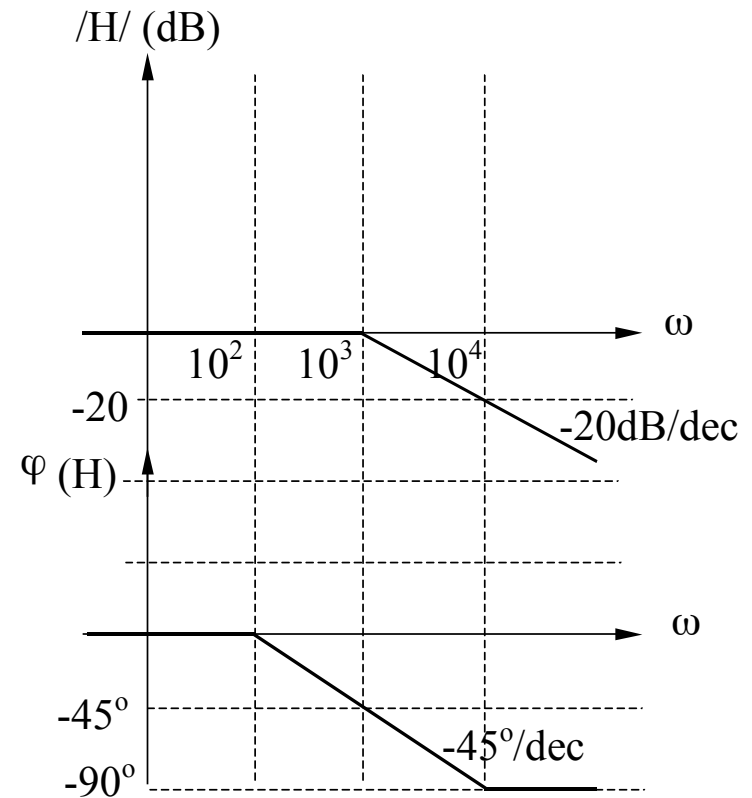

Exemplul 4

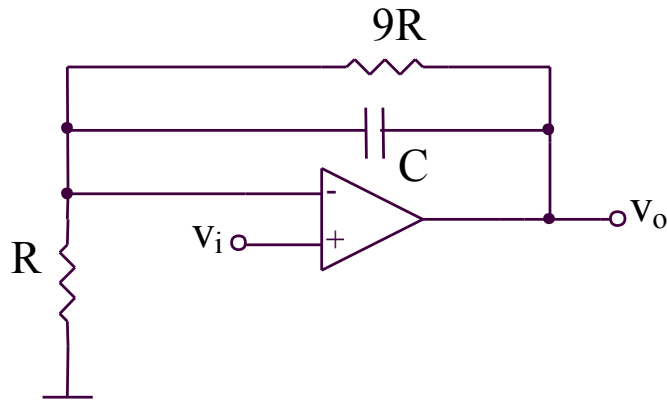

$$RC = 1,11 \times 10^{-3} \text{ s}$$

$$H(j\omega) = \frac{v_o}{v_i} = 1 + \frac{9R}{R} = 10 \frac{1 + 0,9j\omega RC}{1 + 9j\omega RC} = 10 \frac{1 + j \frac{\omega}{10^3}}{1 + j \frac{\omega}{10^2}}$$

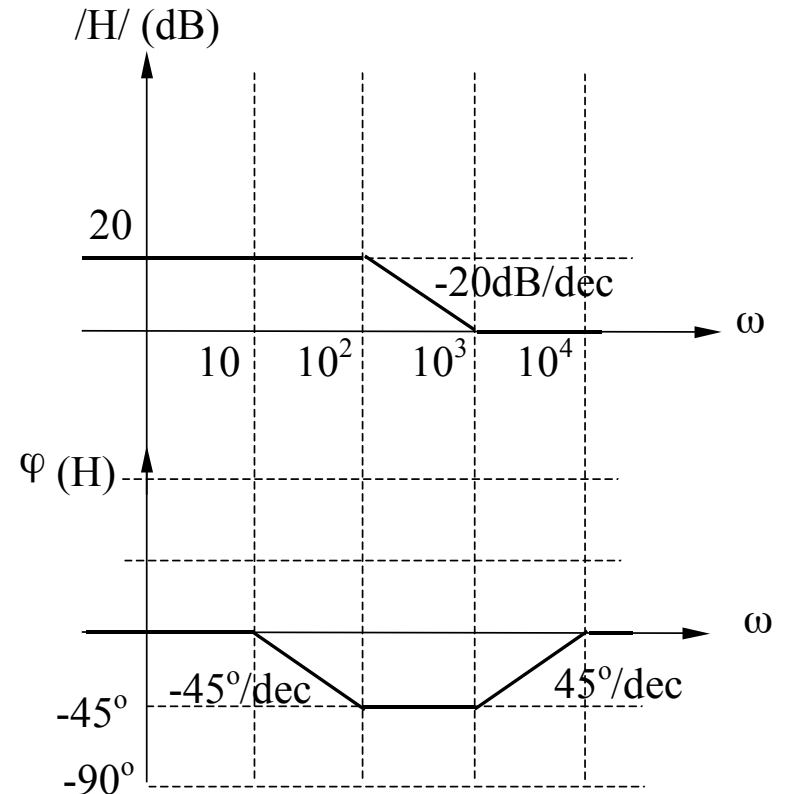

7.2. Raspunsul in frecventa al amplificatoarelor

7.2. Raspunsul in frecventa al amplificatoarelor

7.2.1. Banda de frecventa

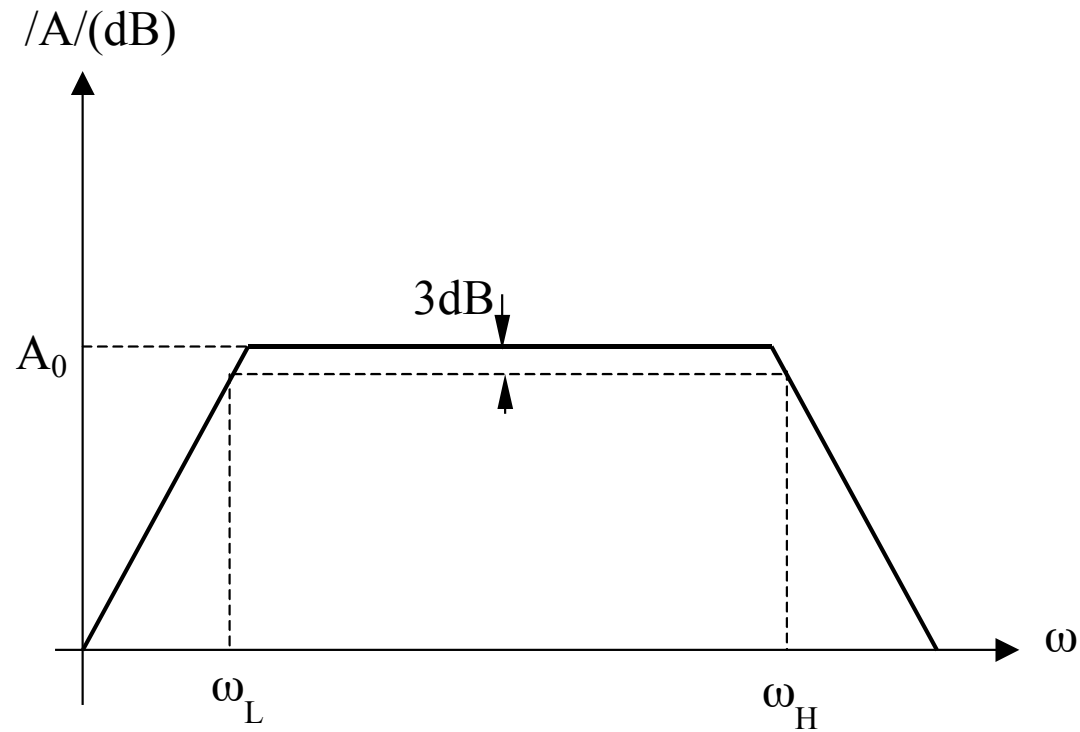

7.2. Raspunsul in frecventa al amplificatoarelor

7.2.1. Banda de frecventa

La frecvente medii:

- condensatoarele de cuplaj si de decuplare sunt scurt-circuite
- condensatoarele interne ale dispozitivelor sunt circuite deschise

La frecvente joase:

- condensatoarele de cuplaj si de decuplare nu mai sunt scurt-circuite
- condensatoarele interne ale dispozitivelor sunt circuite deschise

La frecvente inalte:

- condensatoarele de cuplaj si de decuplare sunt scurt-circuite
- condensatoarele interne ale dispozitivelor nu mai sunt circuite deschise

7.2. Raspunsul in frecventa al amplificatoarelor

7.2.2. Slew-Rate-ul (SR) amplificatoarelor operationale

Slew-Rate-ul (SR) reprezinta viteza maxima de crestere a tensiunii de iesire a unui amplificator operational in CONDITII DE SEMNAL MARE.

Evaluarea performantei la semnal mare si inalta frecventa pentru un AO

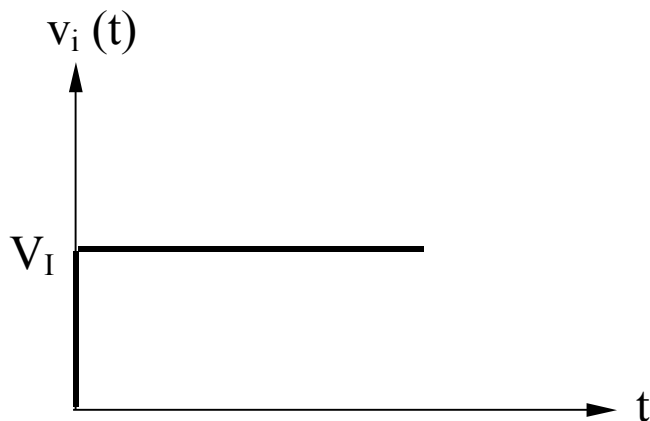
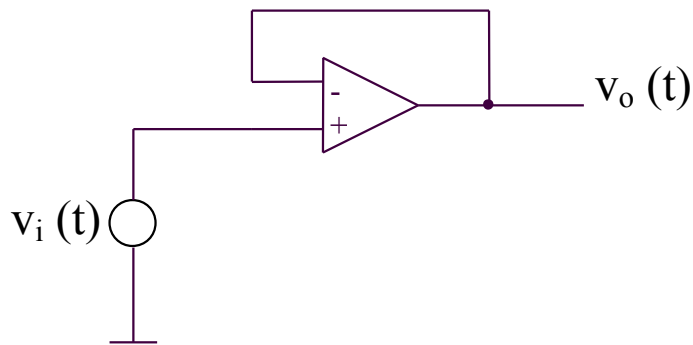

Amplificarea in bucla inchisa are expresia:

$$A = \frac{a}{1 + af}$$

Se considera un AO cu un singur pol:

$$a = \frac{a_0}{1 + \frac{s}{\omega_H}}$$

Circuitul fiind repetor, $f = 1$. Se obtine:

$$A(s) = \frac{V_o(s)}{V_i(s)} = \frac{a(s)}{1 + a(s)} = \frac{1}{1 + \frac{1}{a(s)}} \cong \frac{1}{1 + \frac{s}{\omega_u}}$$

unde:

$$\omega_u = a_0 \omega_H$$

7.2. Raspunsul in frecventa al amplificatoarelor

7.2.2. Slew-Rate-ul (SR) amplificatoarelor operationale

Evaluarea performantei la semnal mare si inalta frecventa pentru un AO

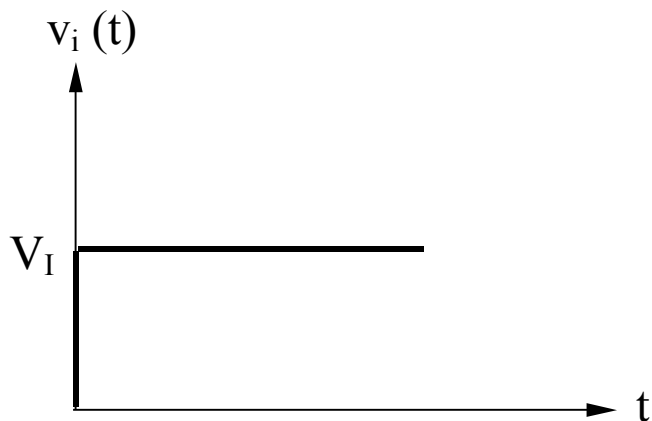
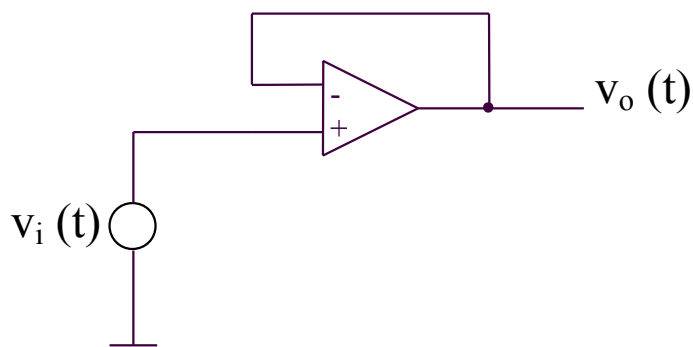

Semnalul de intrare are transformata Laplace:

$$V_i(s) = \frac{V_I}{s}$$

Rezulta:

$$V_o(s) = V_i(s)A(s) = \frac{V_I}{s} \frac{1}{1 + \frac{s}{\omega_u}} =$$

$$= V_I \left(\frac{1}{s} - \frac{1}{s + \omega_u} \right)$$

Deci:

$$v_o(t) = V_I (1 - e^{-\omega_u t})$$

7.2. Raspunsul in frecventa al amplificatoarelor

7.2.2. Slew-Rate-ul (SR) amplificatoarelor operationale

Evaluarea performantei la semnal mare si inalta frecventa pentru un AO

$$V_I(1 - e^{-\omega_u t_{90\%}}) = 0,9V_I \Rightarrow t_{90\%} = -\frac{\ln(0,1)}{\omega_u}$$

$$V_I(1 - e^{-\omega_u t_{10\%}}) = 0,1V_I \Rightarrow t_{10\%} = -\frac{\ln(0,9)}{\omega_u}$$

$$t_r = t_{90\%} - t_{10\%} = \frac{\ln(9)}{\omega_u} \cong \frac{2,2}{\omega_u}$$

Rezulta:

$$t_r \omega_u = 2,2 \quad \text{sau} \quad t_r f_u = 0,35$$

Raspuns in timp estimat

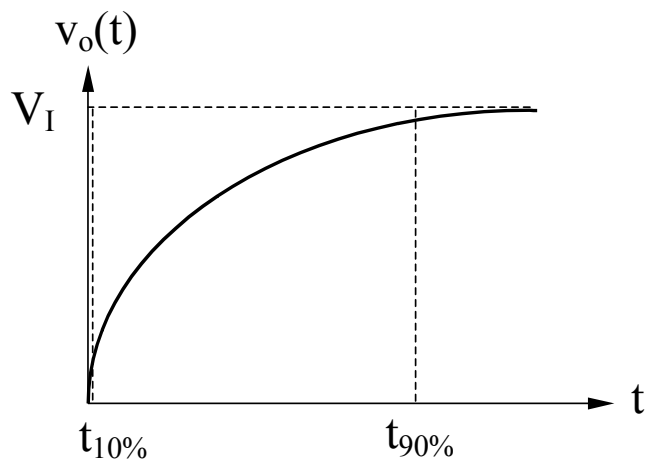

Raspuns in timp masurat

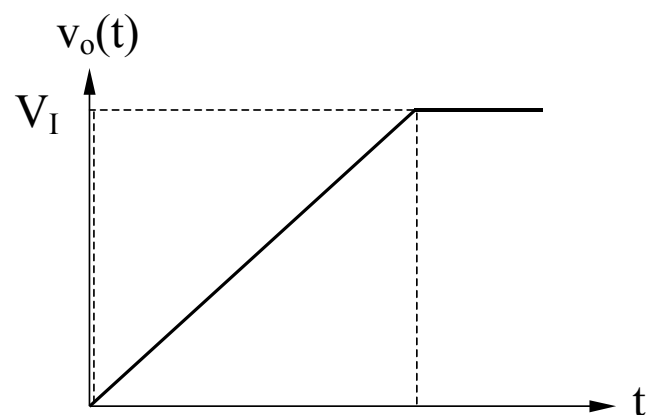

7.2. Raspunsul in frecventa al amplificatoarelor

7.2.2. Slew-Rate-ul (SR) amplificatoarelor operationale

Evaluarea performantei la semnal mare si inalta frecventa pentru un AO

Diferenta majora intre cele doua raspunsuri in timp este cauzata de faptul ca analiza de SEMNAL MIC nu poate fi utilizata pentru a determina comportamentul circuitului in conditii de SEMNAL MARE.

Structura tipica a unui AO este:

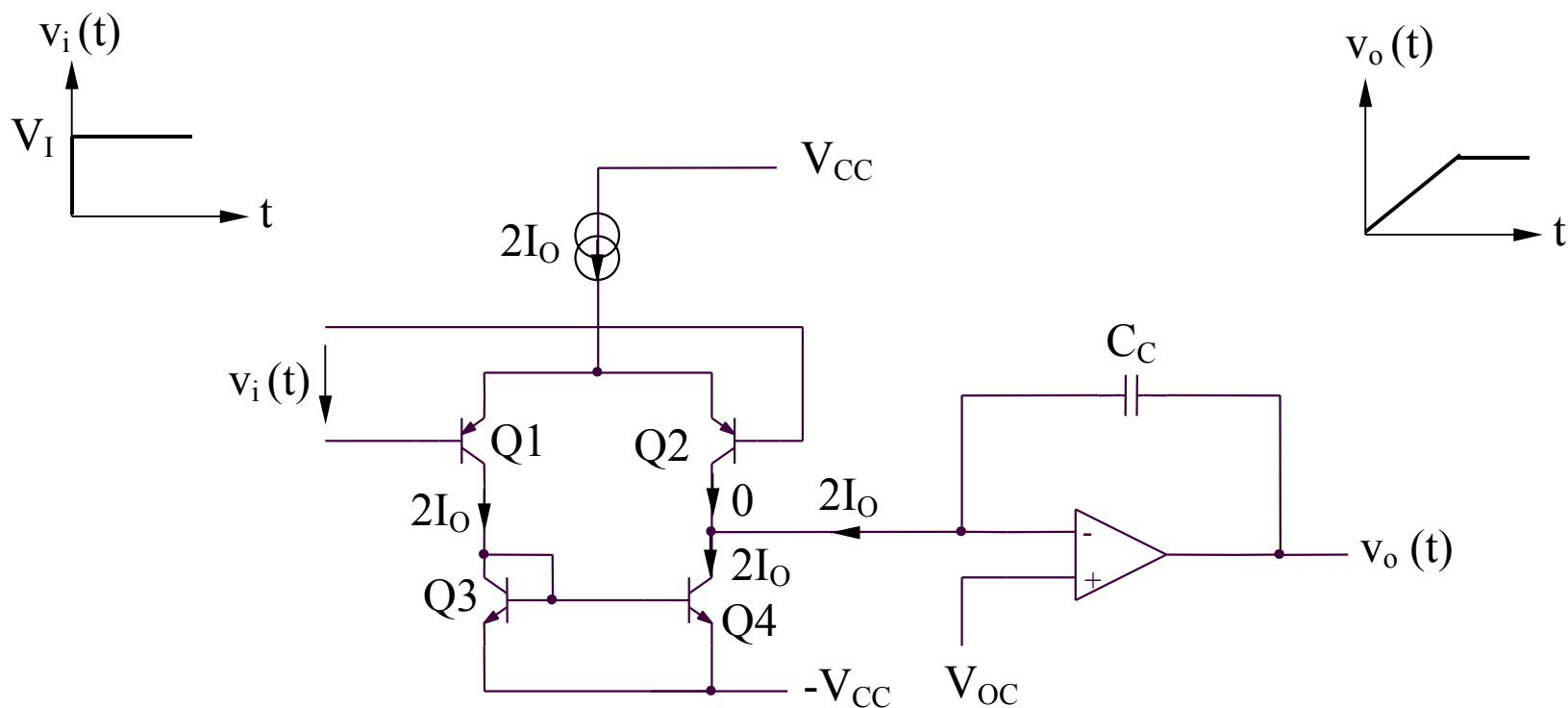

7.2. Raspunsul in frecventa al amplificatoarelor

7.2.2. Slew-Rate-ul (SR) amplificatoarelor operationale

Evaluarea performantei la semnal mare si inalta frecventa pentru un AO

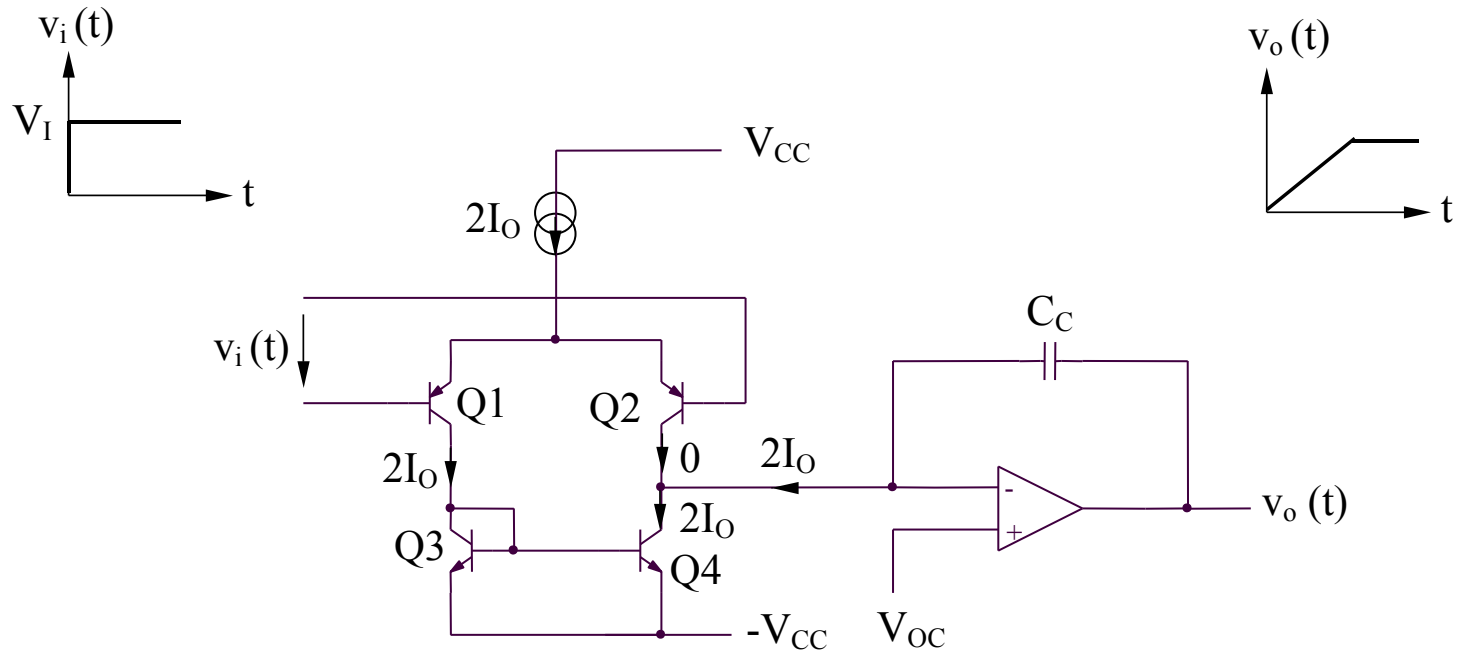

La $t = 0$, semnalul de intrare creste de la 0 la V_I (de ordinul voltilor), dar tensiunea de iesire nu raspunde instantaneu. Tensiunea mare de intrare aplicata AO va scoate complet AD de intrare din zona liniara. Prin urmare, $i_{C2} = 0$, iar $i_{C1} = i_{C3} = i_{C4} = 2I_O$, curent ce va incarca condensatorul C_C la o tensiune v_O , cu o panta $dv_O/dt = SR$:

$$v_O = v_{C_C} = \frac{1}{C_C} \int_0^t 2I_O dt \quad \frac{dv_O}{dt} = \boxed{\frac{2I_O}{C_C} = SR = \text{constant}}$$

7.2. Raspunsul in frecventa al amplificatoarelor

7.2.2. Slew-Rate-ul (SR) amplificatoarelor operationale

Efectul limitarilor introduse de SR asupra functionarii la semnal mare de intrare de tip sinusoidal

Ideal, tensiunea de iesire va urmari tensiunea de intrare:

$$v_o = V_o \sin \omega t$$

cu o viteza de variatie maxima a tensiunii de iesire avand expresia:

$$\left. \frac{dv_o}{dt} \right|_{max} = \omega V_o$$

a. Daca $\left. \frac{dv_o}{dt} \right|_{max} < SR$, v_o va urmari perfect tensiunea de intrare

b. Daca $\left. \frac{dv_o}{dt} \right|_{max} > SR$, v_o va fi afectata de distorsiuni puternice

Frecventa maxima a semnalului de iesire de amplitudine maxima (aproximativ egala cu tensiunea de alimentare) nedistorsionat, f_{max} , se poate determina astfel:

$$\left. \frac{dv_o}{dt} \right|_{max} = \omega_{max} V_{OM} = SR \Rightarrow f_{max} = \frac{SR}{2\pi V_{OM}}$$

7.2. Raspunsul in frecventa al amplificatoarelor

7.2.3. Analiza raspunsului in frecventa al amplificatoarelor elementare

A. Analiza directa

- presupune: - realizarea circuitelor echivalente pornind de la modelele de inalta frecventa ale dispozitivelor constitutive
 - determinarea setului de ecuatii specifice circuitului analizat
 - rezolvarea acestor ecuatii
- prezinta avantajul unui raspuns in frecventa exact
- prezinta dezavantajul major al unei complexitati de calcul foarte ridicate
- este utilizata in special in simulatoare

7.2. Raspunsul in frecventa al amplificatoarelor

7.2.3. Analiza raspunsului in frecventa al amplificatoarelor elementare

Exemple: etajele emitor comun/sursa comuna

Modelul general al etajelor emitor comun/sursa comuna:

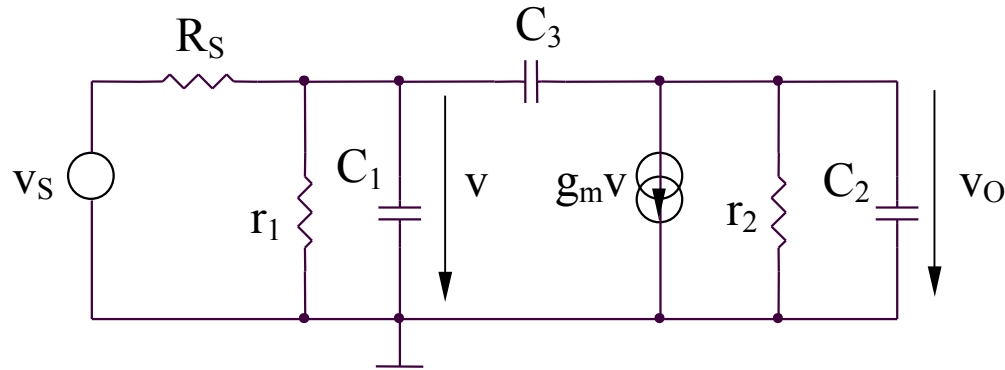

Circuitul echivalent (echivalare Norton):

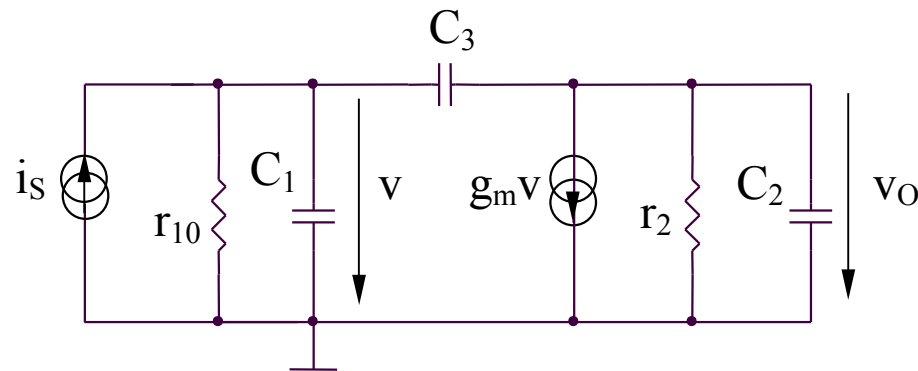

$$i_S = \frac{v_S}{R_S}$$

$$r_{10} = R_S // r_1$$

7.2. Raspunsul in frecventa al amplificatoarelor

7.2.3. Analiza raspunsului in frecventa al amplificatoarelor elementare

Exemple: etajele emitor comun/sursa comuna

Circuitul echivalent (echivalare Norton):

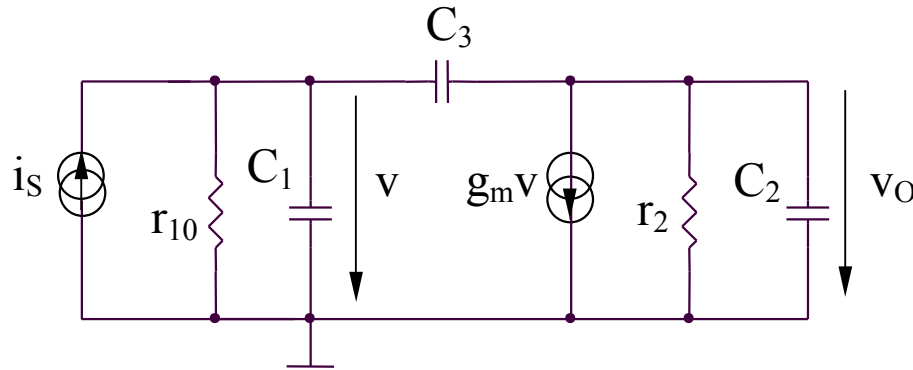

Ecuatiile potentialelor la noduri:

$$v(sC_1 + sC_3 + g_{10}) = i_S + v_O sC_3$$

$$v_O(sC_2 + sC_3 + g_2) = -g_m v + v sC_3$$

Rezulta:

$$\frac{v_O}{v_S} = -g_m r_2 \frac{r_1}{r_1 + R_S} \frac{1 - s \frac{C_3}{g_m}}{1 + s \left[\frac{C_2 + C_3}{g_2} + \frac{C_1 + C_3}{g_1 + G_S} + \frac{g_m C_3}{g_2 (g_1 + G_S)} \right] + s^2 \frac{C_1 C_2 + C_1 C_3 + C_2 C_3}{(g_1 + G_S) g_2}}$$

7.2. Raspunsul in frecventa al amplificatoarelor

7.2.3. Analiza raspunsului in frecventa al amplificatoarelor elementare

Exemple: etajele emitor comun/sursa comuna

Considerand ca circuitul are doi poli reali, p_1 si p_2 , numitorul $P(s)$ al amplificarii poate fi scris astfel:

$$P(s) = \left(1 - \frac{s}{p_1}\right) \left(1 - \frac{s}{p_2}\right) = 1 - \left(\frac{1}{p_1} + \frac{1}{p_2}\right)s + \frac{1}{p_1 p_2} s^2$$

$$P(s) = 1 + a_1 s + a_2 s^2$$

unde:

$$a_1 = -\left(\frac{1}{p_1} + \frac{1}{p_2}\right) \qquad a_2 = \frac{1}{p_1 p_2}$$

Daca se presupune ca exista un pol dominant de inalta frecventa, $|p_1| \ll |p_2|$, rezulta:

$$p_1 = -\frac{1}{a_1} \qquad p_2 = -\frac{a_1}{a_2}$$

7.2. Raspunsul in frecventa al amplificatoarelor

7.2.3. Analiza raspunsului in frecventa al amplificatoarelor elementare

Exemple: etajele emitor comun/sursa comuna

Se obtin urmatoarele expresii aproximative ale polilor:

$$p_1 = -\frac{1}{a_1} = -\frac{1}{\frac{C_2 + C_3}{g_2} + \frac{C_1 + C_3}{g_1 + G_S} + \frac{g_m C_3}{g_2(g_1 + G_S)}} = -\frac{1}{(r_1 // R_S)(C_1 + C_3) + r_2(C_2 + C_3) + g_m r_2(r_1 // R_S)C_3}$$

$$p_2 = -\frac{a_1}{a_2} = -\frac{(g_1 + G_S)(C_2 + C_3) + g_2(C_1 + C_3) + g_m C_3}{C_1 C_2 + C_1 C_3 + C_2 C_3}$$

$$p_2 \cong -\frac{g_m C_3}{C_1 C_2 + C_1 C_3 + C_2 C_3} = -\frac{g_m}{C_1 + C_2 + \frac{C_1 C_2}{C_3}}$$

Concluzii:

- analiza directa necesita un efort de calcul considerabil
- pentru analiza functionarii circuitului la frecvente inalte, daca zeroul nu este dominant, polul cel mai important este acela de modul minim, el determinand valoarea ω_H ($\omega_H = 1/p_1$)
- daca C_3 creste, ω_{p1} scade si ω_{p2} creste, producand indepartarea polilor (poles splitting) si justificand presupunerea $1/p_1 \ll 1/p_2$

7.2. Raspunsul in frecventa al amplificatoarelor

7.2.3. Analiza raspunsului in frecventa al amplificatoarelor elementare

Exemple: etajele emitor comun/sursa comuna

Cazuri particulare

Sursa de tensiune de intrare ideala ($R_S = 0, G_S = \infty$)

$$p_1 = -\frac{g_2}{C_2 + C_3} \qquad p_2 = -\infty$$

Amplificatorul are un singur pol.

Sursa de curent de intrare ideala ($R_S = \infty, G_S = 0$). Considerand $g_m \gg g_1, g_2$, rezulta:

$$p_1 = -\frac{g_1 g_2}{g_m C_3} \qquad p_2 \cong -\frac{g_m}{C_1 + C_2 + \frac{C_1 C_2}{C_3}}$$

7.2. Raspunsul in frecventa al amplificatoarelor

7.2.3. Analiza raspunsului in frecventa al amplificatoarelor elementare

B. Metoda constantelor de timp

- se poate utiliza in situatia existentei unor poli dominanti si a unor zerouri ne-dominante
- permite estimarea aproximativa a ω_L si ω_H

Funcția de transfer a amplificatorului poate fi exprima astfel:

$$A(s) = \frac{a_0 + a_1s + \dots + a_ms^m}{b_0 + b_1s + \dots + b_ns^n} = K \frac{\left(1 - \frac{s}{z_1}\right)\left(1 - \frac{s}{z_2}\right)\dots\left(1 - \frac{s}{z_m}\right)}{\left(1 - \frac{s}{p_1}\right)\left(1 - \frac{s}{p_2}\right)\dots\left(1 - \frac{s}{p_n}\right)}, \quad m < n$$

Un caz frecvent este cel in care funcția de transfer are numai poli (sau zerourile nu sunt importante):

$$A(s) = \frac{K}{\left(1 - \frac{s}{p_1}\right)\left(1 - \frac{s}{p_2}\right)\dots\left(1 - \frac{s}{p_n}\right)}$$

7.2. Raspunsul in frecventa al amplificatoarelor

7.2.3. Analiza raspunsului in frecventa al amplificatoarelor elementare

B. Metoda constantelor de timp

Un caz practic important este cel in care unul din poli este dominant:

$$|p_1| \ll |p_2|, \dots, |p_n|$$

Deci:

$$\frac{1}{|p_1|} \gg \left| \sum_{i=2}^n \left(-\frac{1}{p_i} \right) \right|$$

rezultand:

$$|A(j\omega)| = \frac{K}{\sqrt{\left[1 + \left(\frac{\omega}{p_1}\right)^2\right] \left[1 + \left(\frac{\omega}{p_2}\right)^2\right] \dots \left[1 + \left(\frac{\omega}{p_n}\right)^2\right]}} \cong \frac{K}{\sqrt{\left[1 + \left(\frac{\omega}{p_1}\right)^2\right]}}$$

Aproximatia este corecta cel putin pana la $\omega = |p_1|$. Deci, expresia anterioara aproximativa va permite determinarea corecta a ω_{-3dB} :

$$\omega_{-3dB} = |p_1|$$

7.2. Raspunsul in frecventa al amplificatoarelor

7.2.3. Analiza raspunsului in frecventa al amplificatoarelor elementare

B. Metoda constantelor de timp

B1. Estimarea ω_L utilizand metoda constantelor de timp de scurt-circuit

Pentru un circuit avand n condensatoare de cuplaj si de decuplare, ω_L poate fi determinat astfel:

$$\omega_L \cong \sum_{i=1}^n \frac{1}{R_{iS} C_i}$$

R_{iS} reprezinta rezistenta echivalenta dintre terminalele condensatorului C_i , considerand toate celelalte condensatoare scurt-circuit.

7.2. Raspunsul in frecventa al amplificatoarelor

7.2.3. Analiza raspunsului in frecventa al amplificatoarelor elementare

B. Metoda constantelor de timp

B1. Estimarea ω_L utilizand metoda constantelor de timp de scurt-circuit

Exemplu: amplificatorul emitor comun

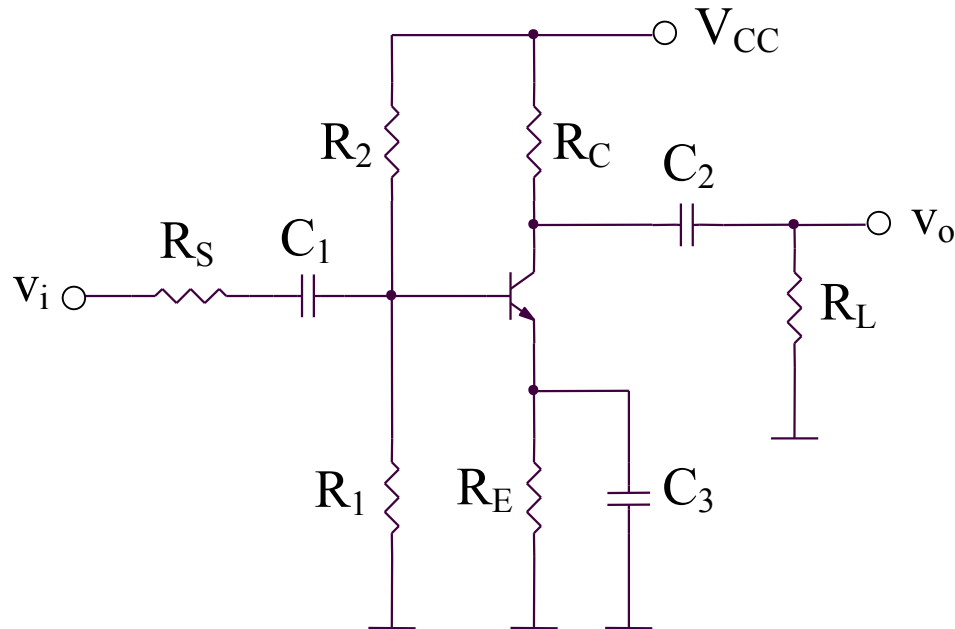

- 3 condensatoare de cuplaj si de decuplare (C_1 , C_2 si C_3)
- 2 condensatoare interne ale tranzistorului (C_π si C_μ)

7.2. Raspunsul in frecventa al amplificatoarelor

7.2.3. Analiza raspunsului in frecventa al amplificatoarelor elementare

B. Metoda constantelor de timp

B1. Estimarea ω_L utilizand metoda constantelor de timp de scurt-circuit

Exemplu: amplificatorul emitor comun

(continuare)

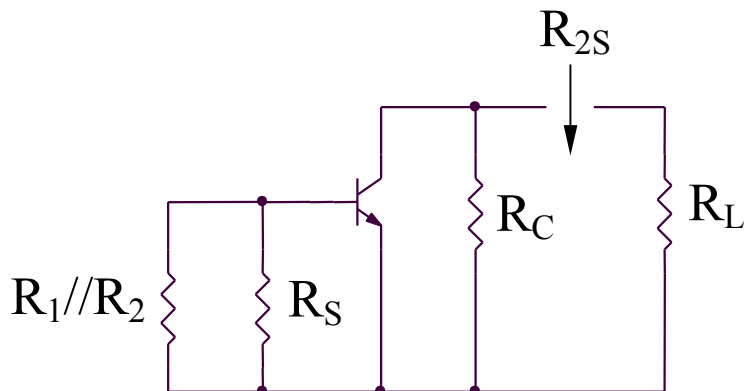
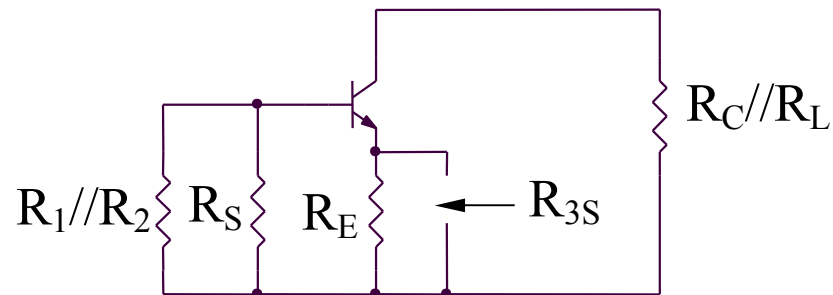
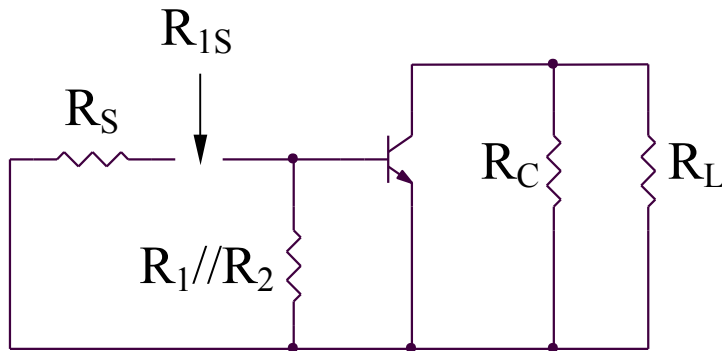

$$R_{1S} = R_S + R_1 // R_2 // r_{\pi}$$

$$R_{2S} = R_L + R_C // r_o$$

$$R_{3S} = R_E // \frac{r_{\pi} + R_S // R_1 // R_2}{\beta + 1}$$

$$\omega_L \cong \sum_{i=1}^3 \frac{1}{R_{iS} C_i} = \frac{1}{R_{1S} C_1} + \frac{1}{R_{2S} C_2} + \frac{1}{R_{3S} C_3}$$

7.2. Raspunsul in frecventa al amplificatoarelor

7.2.3. Analiza raspunsului in frecventa al amplificatoarelor elementare

B. Metoda constantelor de timp

B2. Estimarea ω_H utilizand metoda constantelor de timp de gol

Pentru un circuit avand m condensatoare, ω_H poate fi determinat astfel:

$$\omega_H \cong \frac{1}{\sum_{i=1}^m R_{iO} C_i}$$

R_{iO} reprezinta rezistenta echivalenta dintre terminalele condensatorului C_i , considerand toate celelalte condensatoare considerate a fi circuite deschise. ω_H depinde de toate condensatoarele din modelul de semnal mic si inalta frecventa al circuitului analizat.

Limitari ale metodei:

- nu ofera informatii legate de polii ne-dominanti
- nu ofera informatii asupra zerourilor circuitului analizat

7.2. Raspunsul in frecventa al amplificatoarelor

7.2.3. Analiza raspunsului in frecventa al amplificatoarelor elementare

B. Metoda constantelor de timp

B2. Estimarea ω_H utilizand metoda constantelor de timp de gol (continuare)

Exemple: etajele emitor comun/sursa comuna

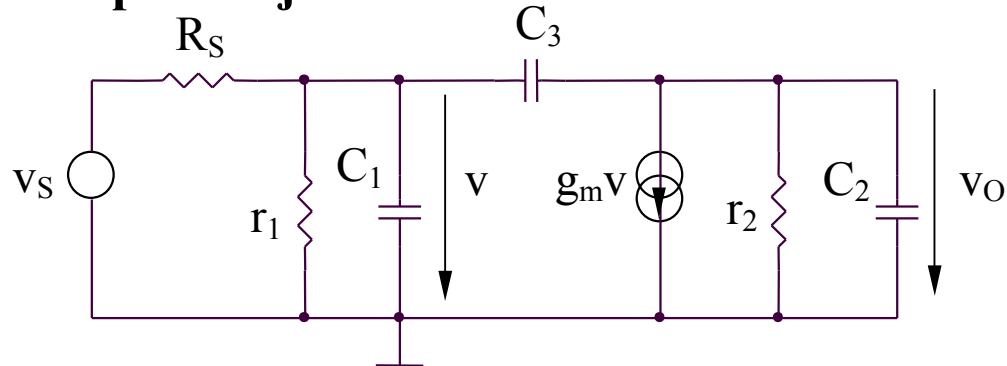

$$\omega_H \cong \frac{1}{\sum_{i=1}^m R_{i0} C_i}$$

Circuitul contine 3 condensatoare, deci va avea 3 constante de timp:

$$\tau_{10} = C_1 R_{10}$$

$$\tau_{20} = C_2 R_{20}$$

$$\tau_{30} = C_3 R_{30}$$

7.2. Raspunsul in frecventa al amplificatoarelor

7.2.3. Analiza raspunsului in frecventa al amplificatoarelor elementare

B. Metoda constantelor de timp

B2. Estimarea ω_H utilizand metoda constantelor de timp de gol (continuare)

Exemple: etajele emitor comun/sursa comuna

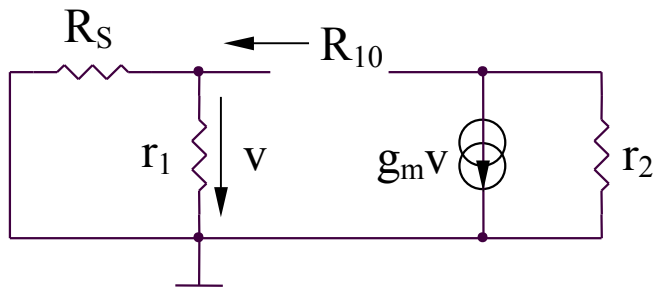

$$R_{10} = r_1 // R_S \Rightarrow \tau_{10} = C_1(r_1 // R_S)$$

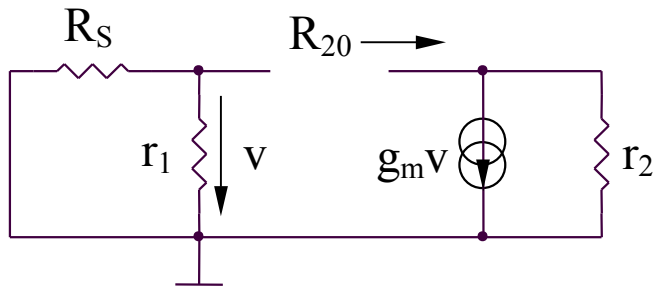

$$R_{20} = r_2 \Rightarrow \tau_{20} = C_2 r_2$$

7.2. Raspunsul in frecventa al amplificatoarelor

7.2.3. Analiza raspunsului in frecventa al amplificatoarelor elementare

B. Metoda constantelor de timp

B2. Estimarea ω_H utilizand metoda constantelor de timp de gol (continuare)

Exemple: etajele emitor comun/sursa comuna

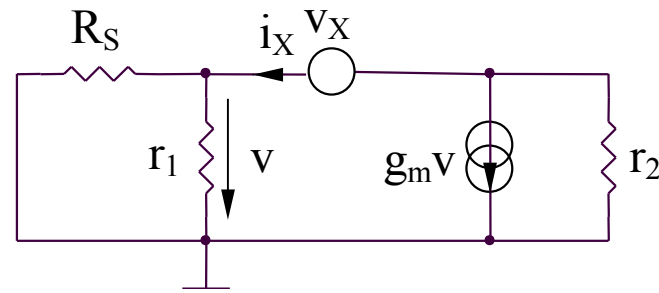
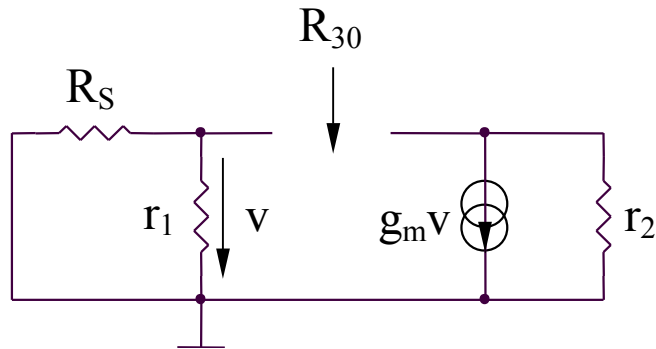

$$\begin{aligned} v_X &= i_X (r_1 // R_S) + (i_X + g_m v) r_2 \\ v &= i_X (r_1 // R_S) \end{aligned} \quad \left| \quad \Rightarrow R_{30} = \frac{v_X}{i_X} = r_1 // R_S + r_2 + g_m r_2 (r_1 // R_S) \right.$$

$$\Rightarrow \tau_{30} = R_{30} C_3 = C_3 [r_1 // R_S + r_2 + g_m r_2 (r_1 // R_S)]$$

7.2. Raspunsul in frecventa al amplificatoarelor

7.2.3. Analiza raspunsului in frecventa al amplificatoarelor elementare

B. Metoda constantelor de timp

B2. Estimarea ω_H utilizand metoda constantelor de timp de gol (continuare)

Exemple: etajele emitor comun/sursa comuna

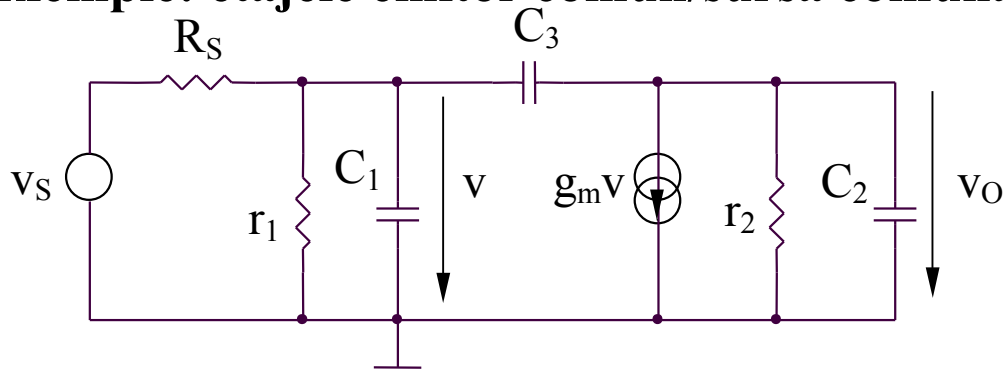

Se obtine:

$$\omega_H = \frac{1}{\tau_{10} + \tau_{20} + \tau_{30}} = \frac{1}{C_1(r_1 // R_S) + C_2 r_2 + C_3 [r_1 // R_S + r_2 + g_m r_2 (r_1 // R_S)]}$$

Pozitia zerorului ω_Z se obtine din conditia ca semnalul prin condensatorul C_3 sa anuleze semnalul prin sursa de curent controlata in tensiune:

$$\begin{aligned} v_O(sC_2 + sC_3 + g_2) &= \Rightarrow \frac{v}{1/\omega_Z C_3} = g_m v \Rightarrow \omega_Z = \frac{g_m}{C_3} \\ &= -g_m v + v s C_3 \end{aligned}$$

7.2. Raspunsul in frecventa al amplificatoarelor

7.2.3. Analiza raspunsului in frecventa al amplificatoarelor elementare

C. Teorema lui Miller

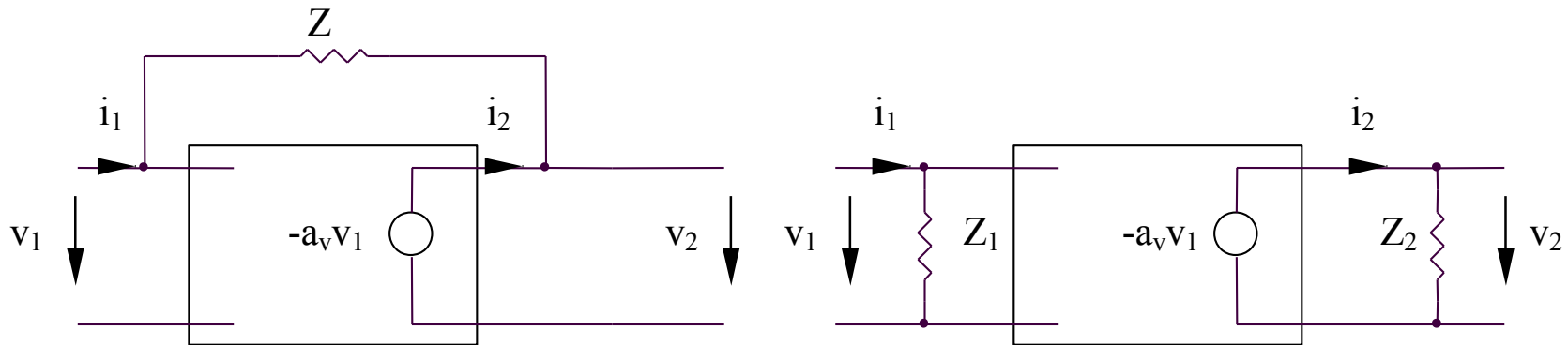

(a)

(b)

$$i_1 = \frac{v_1 - v_2}{Z} = \frac{v_1 + a_v v_1}{Z} = \frac{(1 + a_v)v_1}{Z}$$

$$i_1 = \frac{v_1}{Z_1}$$

$$i_2 = \frac{v_2 - v_1}{Z} = -\frac{(1 + a_v)v_1}{Z}$$

$$i_2 = \frac{v_2}{Z_2} = -\frac{a_v v_1}{Z_2}$$

$$\Rightarrow Z_1 = \frac{Z}{1 + a_v} \ll Z; \quad Z_2 = Z \frac{a_v}{1 + a_v} \cong Z$$

7.2. Raspunsul in frecventa al amplificatoarelor

7.2.3. Analiza raspunsului in frecventa al amplificatoarelor elementare

C. Teorema lui Miller

Exemple: etajele emitor comun/sursa comuna

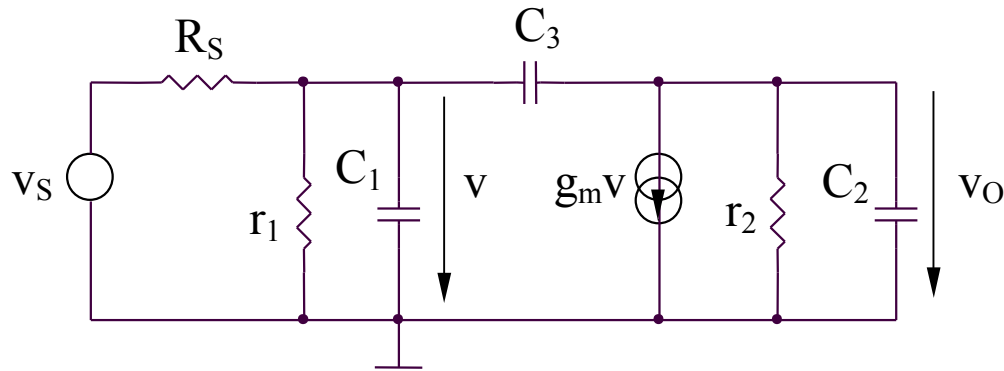

Schema echivalenta (utilizand teorema lui Miller)

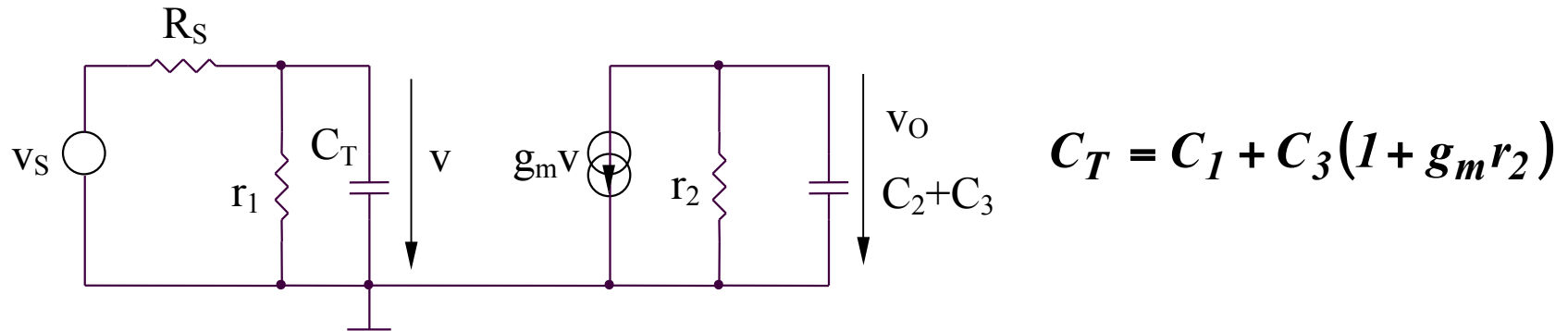

7.2. Raspunsul in frecventa al amplificatoarelor

7.2.3. Analiza raspunsului in frecventa al amplificatoarelor elementare

C. Teorema lui Miller

Exemple: etajele emitor comun/sursa comuna

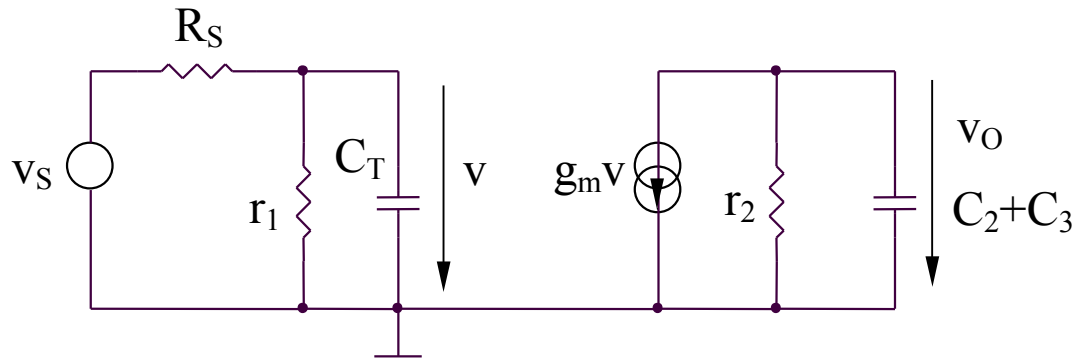

Concluzii:

- aplicarea teoremei lui Miller conduce la obtinerea aceleiasi constante de timp dominante ca si in cazul utilizarii metodei constantelor de timp de gol:

$$\tau \cong C_3 g_m r_2 (r_1 // R_S)$$

- metoda poate fi aplicata numai pentru amplificatoare inversoare avand un condensator cuplat intre intrare si iesire

7.2. Raspunsul in frecventa al amplificatoarelor

7.2.4. Analiza raspunsului in frecventa al amplificatorului diferential

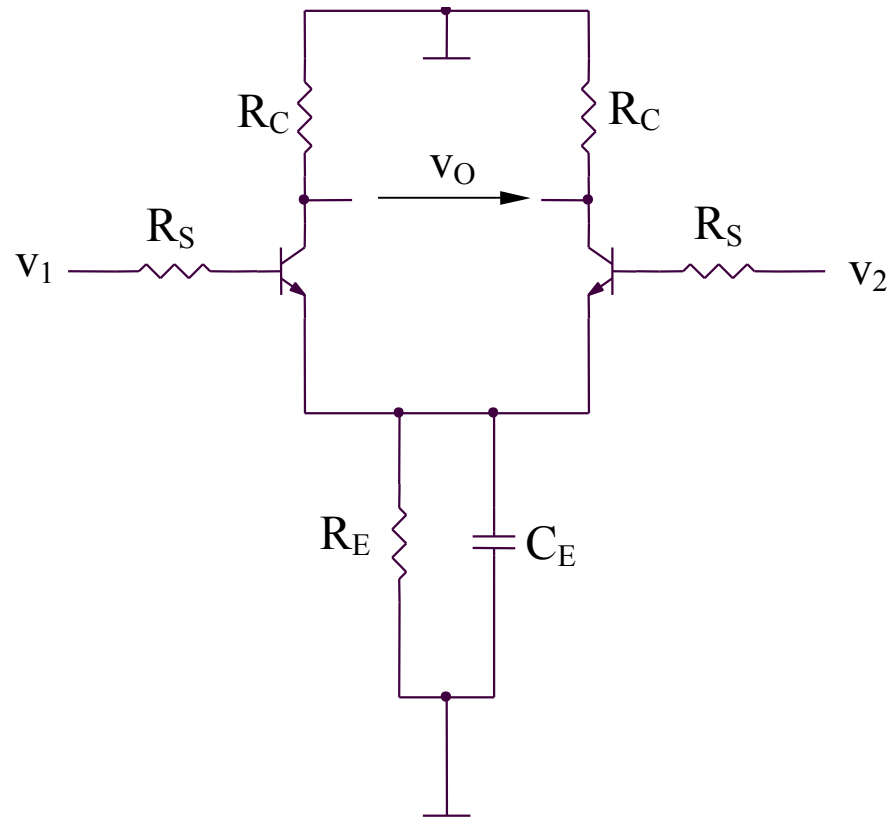

7.2. Raspunsul in frecventa al amplificatoarelor

7.2.4. Analiza raspunsului in frecventa al amplificatorului diferential

Functionarea pe mod diferential (MD)

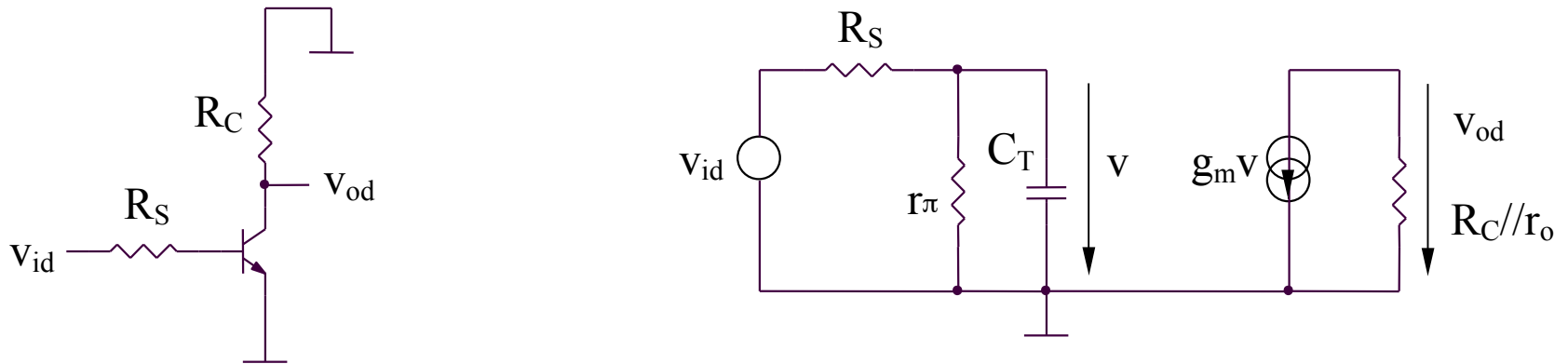

$$A_{dd}(j\omega) = \frac{v_{od}}{v_{id}}(j\omega) = -g_m(R_C // r_o) \frac{r_\pi}{r_\pi + R_S} \frac{1}{1 + j\omega C_T(r_\pi // R_S)}$$

$$A_{dd}(j\omega) = \frac{A_{dd0}}{1 + j \frac{\omega}{\omega_{H(MD)}}}$$

$$A_{dd0} = -g_m(R_C // r_o) \frac{r_\pi}{r_\pi + R_S}$$

$$\omega_{H(MD)} = \frac{1}{(r_\pi // R_S)C_T} = \frac{1}{(r_\pi // R_S) \{C_\pi + C_\mu [1 + g_m(R_C // r_o)]\}}$$

7.2. Raspunsul in frecventa al amplificatoarelor

7.2.4. Analiza raspunsului in frecventa al amplificatorului diferential

Functionarea pe mod comun (MC)

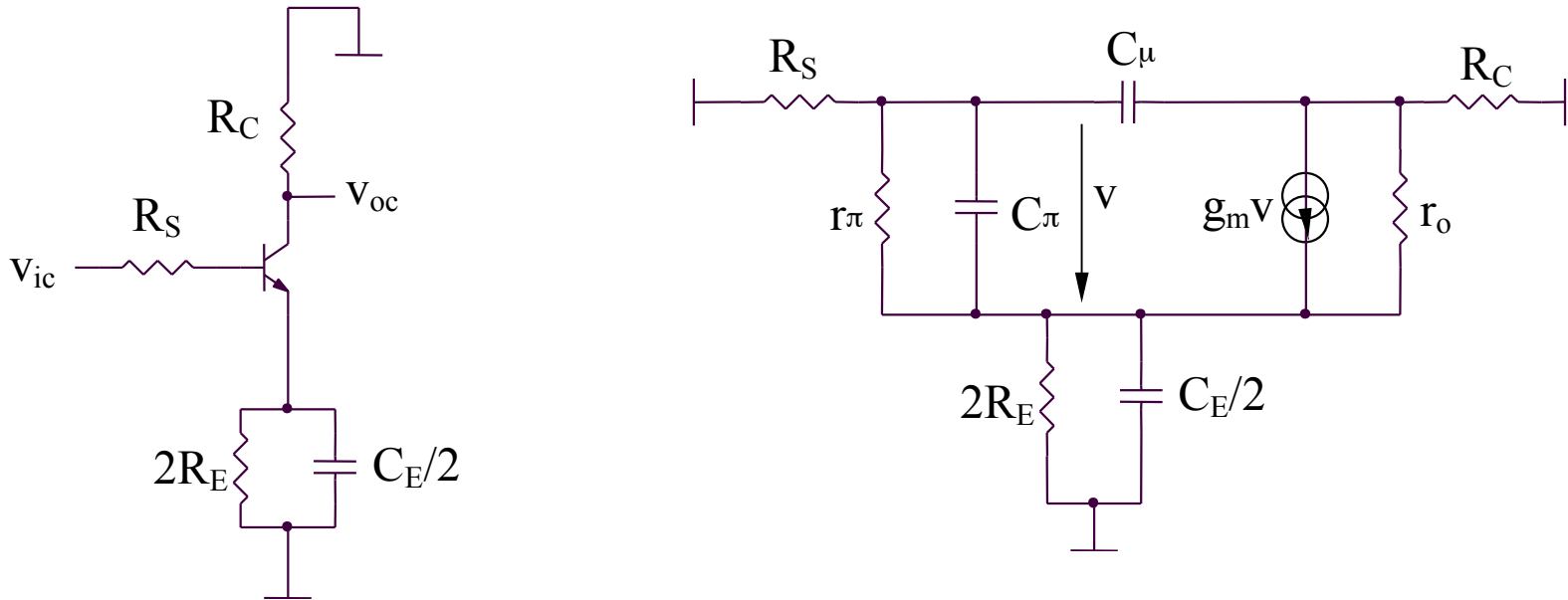

Aplicand metoda constantelor de timp de gol se obtine:

$$\omega_{H(MC)} = \frac{1}{\tau_{E0} + \tau_{\pi0} + \tau_{\mu0}}$$

7.2. Raspunsul in frecventa al amplificatoarelor

7.2.4. Analiza raspunsului in frecventa al amplificatorului diferential

Functionarea pe mod comun (MC)

$$\tau_{E0} = \frac{C_E}{2} \left(2R_E // \frac{r_\pi + R_S}{\beta + 1} \right)$$

Circuit pentru calculul $\tau_{\pi 0}$

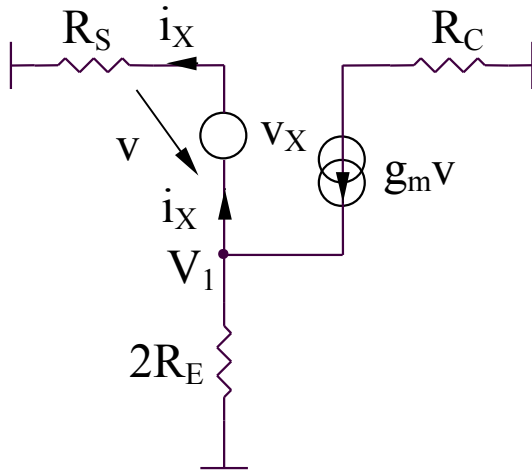

$$\begin{aligned} v_X &= i_X R_S - V_1 \\ \frac{V_1}{2R_E} &= -i_X + g_m v_X \end{aligned} \quad \left| \quad \Rightarrow \quad \frac{i_X R_S - v_X}{2R_E} = -i_X + g_m v_X \right.$$

Se obtin:

$$R_{\pi 0} = \frac{v_X}{i_X} // r_\pi = \frac{2R_E + R_S}{1 + 2g_m R_E} // r_\pi \quad \tau_{\pi 0} = C_\pi \left[\frac{2R_E + R_S}{1 + 2g_m R_E} // r_\pi \right]$$

7.2. Raspunsul in frecventa al amplificatoarelor

7.2.4. Analiza raspunsului in frecventa al amplificatorului diferential

Functionarea pe mod comun (MC)

Circuit pentru calculul $\tau_{\mu 0}$

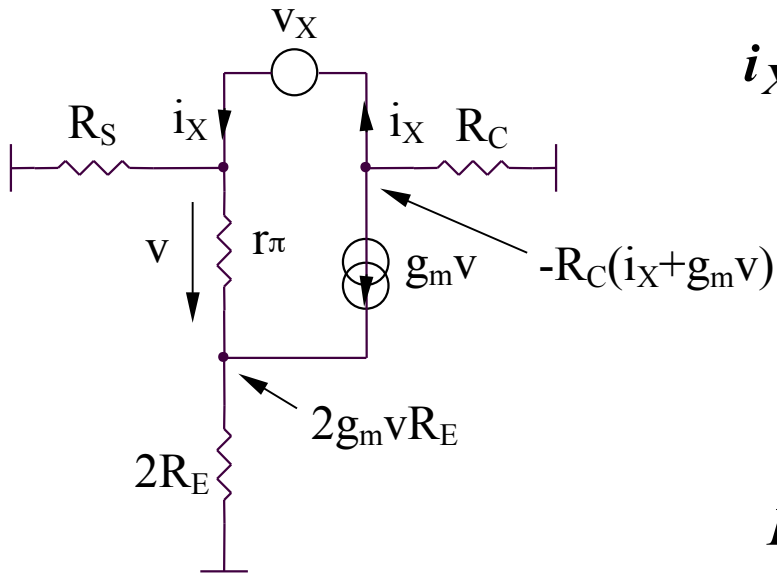

$$i_X = \frac{v}{r_\pi} + \frac{v + 2g_m R_E v}{R_S} = \frac{R_S + r_\pi(1 + 2g_m R_E)}{r_\pi R_S} v$$

$$v_X = (v + 2g_m R_E v) + R_C(i_X + g_m v)$$

Rezulta:

$$R_{\mu 0} = \frac{v_X}{i_X} \cong R_S + R_C + \frac{g_m}{1 + 2g_m R_E} R_S R_C$$

$$\tau_{\mu 0} \cong C_\mu \left(R_S + R_C + \frac{g_m}{1 + 2g_m R_E} R_S R_C \right)$$

7.2. Raspunsul in frecventa al amplificatoarelor

7.2.4. Analiza raspunsului in frecventa al amplificatorului diferential

Functionarea pe mod comun (MC)

Observatie

Amplificarea de mod comun are expresia aproximativa:

$$A_{cc} \cong -\frac{R_C}{2R_E // (2 / j\omega C_E)} = -\frac{R_C}{2R_E} (1 + j\omega C_E R_E)$$

deci condensatorul $C_E/2$ introduce un zero la ω_Z avand expresia:

$$\omega_Z = -\frac{1}{R_E C_E}$$

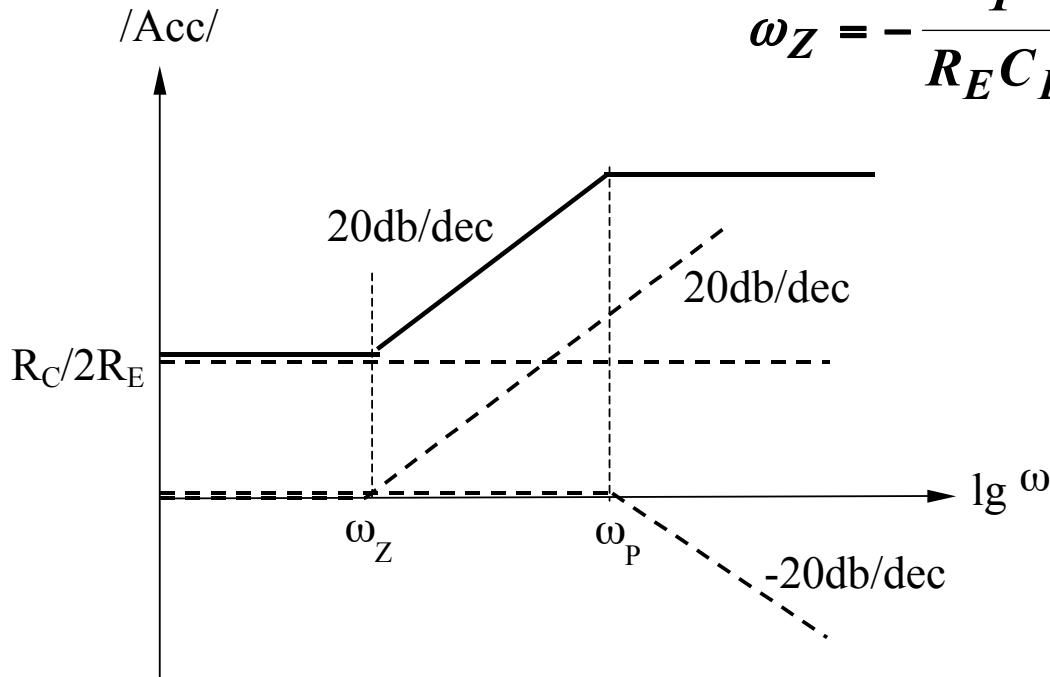

A_{cc} creste o data cu cresterea frecventei

7.3. Raspunsul in frecventa al amplificatoarelor cu reactie

7.3. Raspunsul in frecventa al amplificatoarelor cu reactie

7.3.1. Diagrama bloc a amplificatorului cu reactie

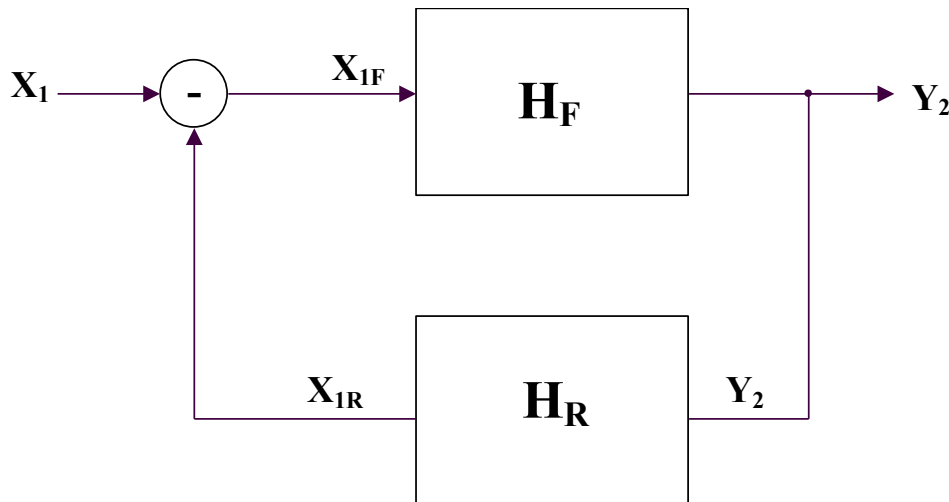

$$Y_2 = H_F X_{1F}$$

$$X_{1R} = H_R Y_2$$

$$X_{1F} = X_1 - X_{1R} = X_1 - H_F H_R X_{1F}$$

X_1, Y_2 sunt curenti/tensiuni

Amplificarea globala:
$$H = \frac{Y_2}{X_1} = \frac{H_F}{1 + H_R H_F}$$

7.3. Raspunsul in frecventa al amplificatoarelor cu reactie

7.3.2. Tipuri de reactie

- Reactie pozitiva: $H > H_F$ $1 + H_F H_R < 1$

- Reactie negativa: $H < H_F$ $1 + H_F H_R > 1$

Caz particular: reactie negativa puternica

Se defineste transmisia pe bucla: $T = \frac{X_{1R}}{X_{1F}} = H_F H_R \gg 1$ ($|H| \ll |H_F|$)

Rezulta: $H|_{T \gg 1} = \frac{H_F}{H_F H_R} = \frac{1}{H_R}$ - independenta de amplificator

Concluzie: pentru reactie negativa puternica, amplificarea cu reactie depinde doar de reactie

7.3. Raspunsul in frecventa al amplificatoarelor cu reactie

7.3.3. Efectele reactiei

A. De-sensibilizarea amplificatorului

$$\frac{dH}{dH_F} = \frac{d}{dH_F} \left(\frac{H_F}{1 + H_F H_R} \right) = \frac{1}{(1 + H_F H_R)^2}$$

$$\left| \frac{dH}{H} \right| = \frac{1}{|1 + H_R H_F|} \left| \frac{dH_F}{H_F} \right| = \frac{1}{|F|} \left| \frac{dH_F}{H_F} \right|$$

$$F = 1 + H_R H_F = 1 + T$$

Reducerea distorsiunilor

Reactia reduce efectul distorsiunilor.

7.3. Raspunsul in frecventa al amplificatoarelor cu reactie

7.3.3. Efectele reactiei

B. Imbunatatirea raspunsului in frecventa

Pentru ω_{\min}

Considerand ca amplificatorul direct este caracterizat de o functie de ordin I:

$$H_F(j\omega) = H_{F0} \frac{\frac{j\omega}{\omega_{F\min}}}{1 + \frac{j\omega}{\omega_{F\min}}}$$

$\frac{j\omega}{\omega_{F\min}}$ H_1
 $\frac{j\omega}{\omega_{F\min}}$ H_2

si ca exista o reactie negativa constanta, H_{R0} ,
rezulta:

$$H(j\omega) = \frac{H_F(j\omega)}{1 + H_F(j\omega)H_{R0}}$$

Deci:

$$H(j\omega) = \frac{H_{F0} \frac{j\omega}{\omega_{F\min}}}{1 + \frac{j\omega}{\omega_{F\min}} + H_{F0}H_{R0} \frac{j\omega}{\omega_{F\min}}}$$

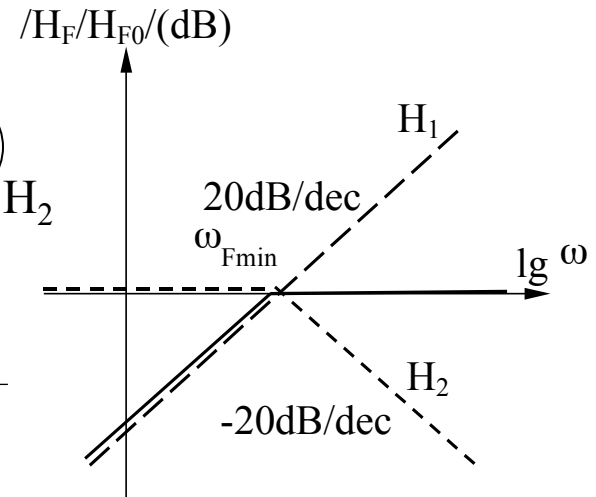

7.3. Raspunsul in frecventa al amplificatoarelor cu reactie

7.3.3. Efectele reactiei

B. Imbunatatirea raspunsului in frecventa

Pentru ω_{\min}

Echivalent cu:

$$H(j\omega) = \frac{H_{F0}}{1 + H_{F0}H_{R0}} \frac{\frac{j\omega}{\omega_{F\min}} (1 + H_{F0}H_{R0})}{1 + \frac{j\omega}{\omega_{F\min}} (1 + H_{F0}H_{R0})}$$

Se poate identifica forma urmatoare a $H(j\omega)$:

$$H(j\omega) = H_0 \frac{\frac{j\omega}{\omega_{\min}}}{1 + \frac{j\omega}{\omega_{\min}}}$$

H_1
 H_2

unde:

$$H_0 = \frac{H_{F0}}{1 + H_{F0}H_{R0}} \quad \omega_{\min} = \frac{\omega_{F\min}}{1 + H_{F0}H_{R0}}$$

7.3. Raspunsul in frecventa al amplificatoarelor cu reactie

7.3.3. Efectele reactiei

B. Imbunatatirea raspunsului in frecventa

Pentru ω_{min}

Concluzie: ω_{min} pentru amplificatorul cu reactie se reduce cu acelasi factor cu care scade amplificarea

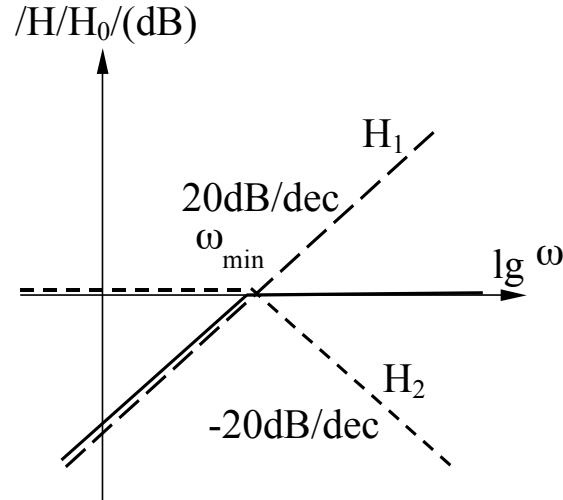

7.3. Raspunsul in frecventa al amplificatoarelor cu reactie

7.3.3. Efectele reactiei

B. Imbunatatirea raspunsului in frecventa

Pentru ω_{\max}

Considerand ca amplificatorul direct este caracterizat de o functie de ordin I:

$$H_F(j\omega) = \frac{H_{F0}}{1 + \frac{j\omega}{\omega_{F\max}}}$$

si ca exista o reactie negativa constanta, H_{R0} ,
rezulta:

$$H(j\omega) = \frac{H_F(j\omega)}{1 + H_F(j\omega)H_{R0}}$$

Deci::

$$H(j\omega) = \frac{H_{F0}}{1 + H_{F0}H_{R0} + \frac{j\omega}{\omega_{F\max}}}$$

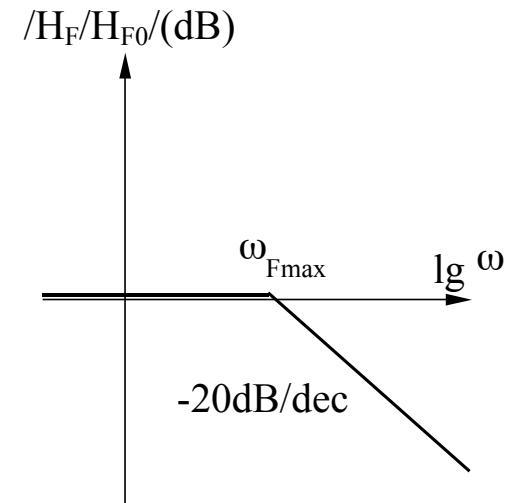

7.3. Raspunsul in frecventa al amplificatoarelor cu reactie

7.3.3. Efectele reactiei

B. Imbunatatirea raspunsului in frecventa

Pentru ω_{\max}

Echivalent cu:

$$H(j\omega) = \frac{H_{F0}}{1 + H_{F0}H_{R0}} \frac{1}{1 + \frac{j\omega}{\omega_{F\max}(1 + H_{F0}H_{R0})}}$$

Se poate identifica forma urmatoare a $H(j\omega)$:

$$H(j\omega) = H_0 \frac{1}{1 + \frac{j\omega}{\omega_{\max}}}$$

unde:

$$H_0 = \frac{H_{F0}}{1 + H_{F0}H_{R0}}$$

$$\omega_{\max} = \omega_{F\max}(1 + H_{F0}H_{R0})$$

Produsul amplificare-banda este constant, $H_0 \omega_{\max} = H_{F0} \omega_{F\max}$.

7.3. Raspunsul in frecventa al amplificatoarelor cu reactie

7.3.3. Efectele reactiei

B. Imbunatatirea raspunsului in frecventa

Pentru ω_{max}

Concluzie: ω_{max} pentru amplificatorul cu reactie creste cu acelasi factor cu care scade amplificarea

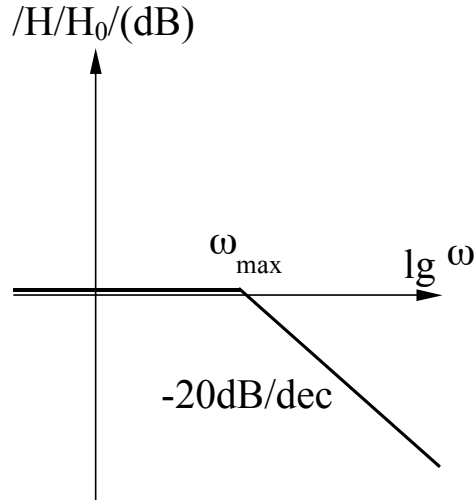

7.3. Raspunsul in frecventa al amplificatoarelor cu reactie

7.3.3. Efectele reactiei

B. Imbunatatirea raspunsului in frecventa

Concluzie:

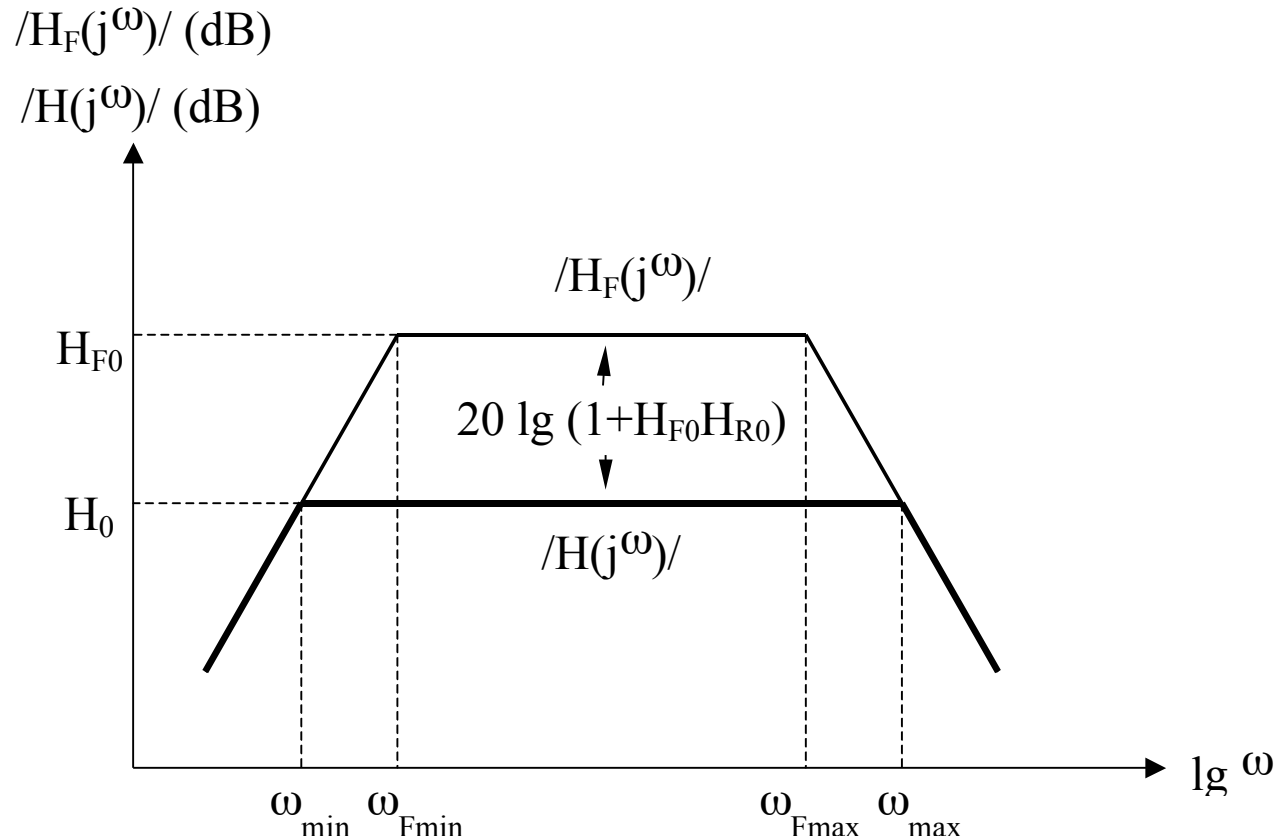

7.3. Raspunsul in frecventa al amplificatoarelor cu reactie

7.3.3. Efectele reactiei

C. Impactul asupra rezistentelor de intrare/iesire

$$R_i' = R_i(1 + T) \quad \text{pentru reactie serie}$$

$$R_i' = R_i(1 + T)^{-1} \quad \text{pentru reactie paralel}$$

$$R_o' = R_o(1 + T) \quad \text{pentru reactie serie}$$

$$R_o' = R_o(1 + T)^{-1} \quad \text{pentru reactie paralel}$$

7.4. Stabilitatea circuitelor

7.4. Stabilitatea circuitelor

7.4.1. Generalitati

Un circuit este stabil daca:

- amplitudinea semnalului de iesire descreste in timp la aplicarea unui semnal treapta pe intrare

sau

- un semnal de intrare de amplitudine limitata produce un semnal de iesire de amplitudine limitata

Amplificarea in bucla inchisa a unui amplificator cu reactie are expresia:

$$A(s) = \frac{a(s)}{1 + a(s)f(s)} = \frac{a(s)}{1 + T(s)}$$

Pozitia polilor si zerourilor functiei de transfer $A(s)$ determina comportamentul amplificatorului cu reactie.

7.4. Stabilitatea circuitelor

7.4.1. Generalitati

Pozitia polilor si zerourilor functiei de transfer $A(s)$ determina comportamentul amplificatorului cu reactie:

Poli reali

- polii reali negativi $s = -\sigma$ ($\sigma > 0$) vor conduce la obtinerea unui raspuns tranzitoriu de forma $\exp(-\sigma t)$, descrescator in timp
- polii reali pozitivi $s = \sigma$ ($\sigma > 0$) vor conduce la obtinerea unui raspuns tranzitoriu de forma $\exp(\sigma t)$, tinzand la infinit (semnalul de iesire va fi limitat de amplificator)

-Poli complex conjugati

- polii complex conjugati $s = -\sigma - j\omega$ ($\sigma > 0$) vor conduce la obtinerea unui raspuns tranzitoriu de forma $\exp(-\sigma t) (A \cos \omega t + B \sin \omega t)$
 - daca $\sigma > \omega$, raspunsul tranzitoriu descreste rapid pentru un ciclu al sinusoidelor
 - daca $\sigma \ll \omega$, vor aparea multe oscilatii inainte de scaderea amplitudinii semnalului de iesire
- polii complex conjugati $s = \sigma + j\omega$ vor conduce la obtinerea unui raspuns tranzitoriu de forma $\exp(\sigma t) (A \cos \omega t + B \sin \omega t)$, a carui amplitudine creste in timp

Concluzie: Un sistem cu reactie este stabil numai daca toti polii functiei sale de transfer in bucla inchisa sunt plasati in partea stanga a planului complex $s = \sigma + j\omega$ (echivalent cu o valoare negativa a partii reale a polilor).

7.4.2. Algoritm pentru evaluarea stabilitatii unui circuit

1. Se pasivizeaza tensiunea de intrare
2. Se intrerupe bucla de reactie intr-un punct
3. Se aplica o tensiune de test, V_t in acest punct
4. Se calculeaza tensiunea transmisa in acelasi punct in urma parcurgerii buclei de reactie, V_{tr}
5. Se calculeaza transmisia pe bucla, $T = V_{tr}/V_t$
6. Se traseaza diagramele Bode pentru T
7. Se traseaza o linie orizontala la -180°
 - A. Daca orizontala nu intersecteaza graficul fazei, circuitul este stabil
 - B. Daca orizontala intersecteaza graficul fazei in punctul A, din A se ridica o axa verticala care va intersecta graficul modulului in punctul B
 - a. daca $|T|_B > 0$, circuitul este instabil
 - b. daca $|T|_B = 0$, circuitul este la limita de stabilitate
 - c. daca $|T|_B < 0$, circuitul este stabil
8. Pentru circuite stabile se poate determina *rezerva de faza* astfel:
 - se noteaza cu C (pe graficul modulului) punctul in care $|T| = 0$
 - se coboara din punctul C o axa verticala care va intersecta graficul fazei in punctul D
 - rezerva de faza este $\Delta\varphi = 180^\circ + \varphi(D)$

7.4.3. Exemple

Exemplul 1. Evaluati stabilitatea urmatorului circuit

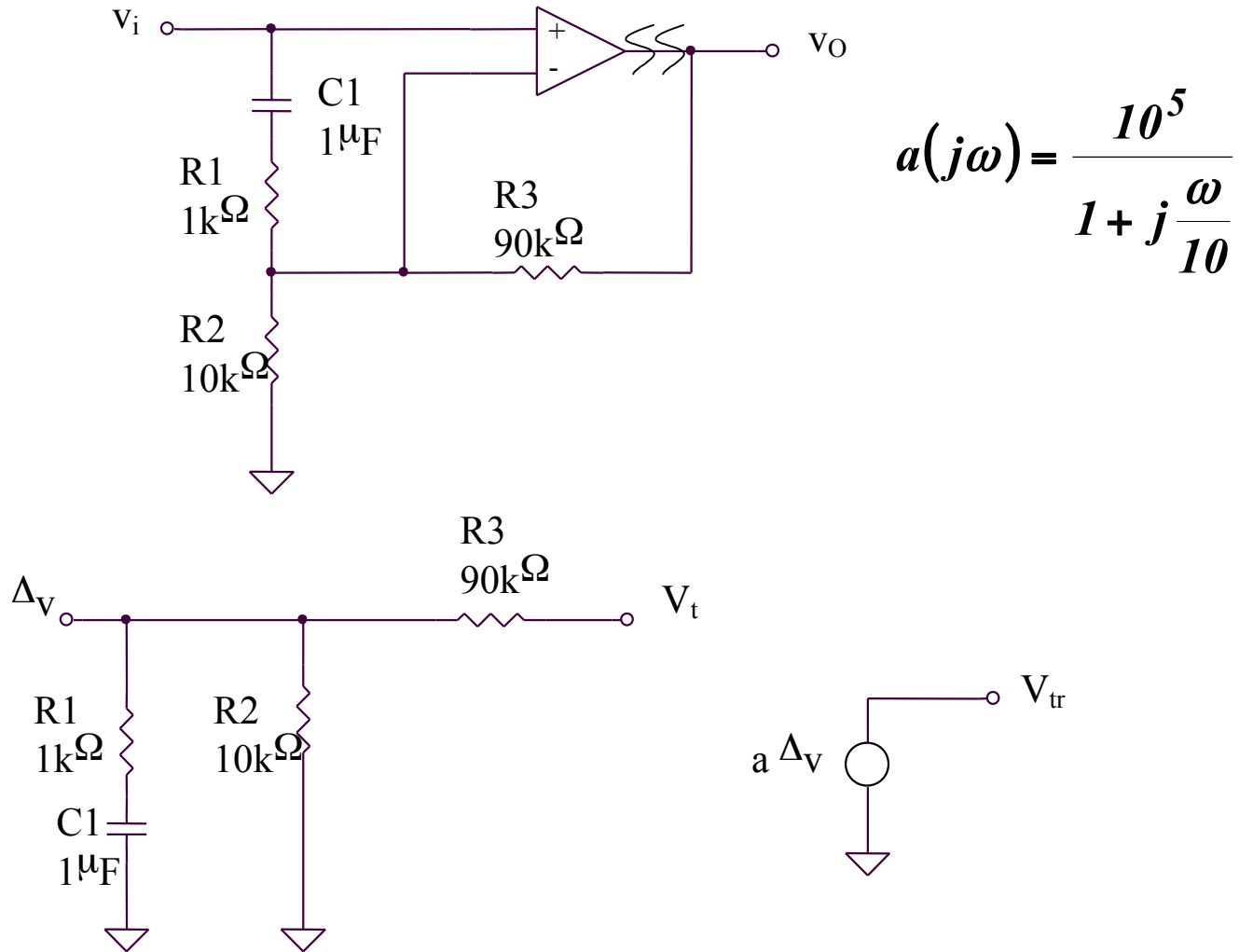

7.4.3. Exemple

Exemplul 1. Evaluati stabilitatea urmatorului circuit

$$T = \frac{V_{tr}}{V_t} = \frac{a\Delta v}{V_t} = a \frac{R_2 // (R_1 + X_{C1})}{R_2 // (R_1 + X_{C1}) + R_3}$$

$$T = a \frac{\frac{R_2(1 + j\omega C_1 R_1)}{1 + j\omega C_1(R_1 + R_2)}}{\frac{R_2(1 + j\omega C_1 R_1)}{1 + j\omega C_1(R_1 + R_2)} + R_3} = a \frac{R_2}{R_2 + R_3} \frac{1 + j\omega C_1 R_1}{1 + j\omega C_1 [R_1 + (R_2 // R_3)]}$$

$$T = 10^4 \frac{1 + j \frac{\omega}{10^3}}{\left(1 + j \frac{\omega}{10}\right) \left(1 + j \frac{\omega}{10^2}\right)}$$

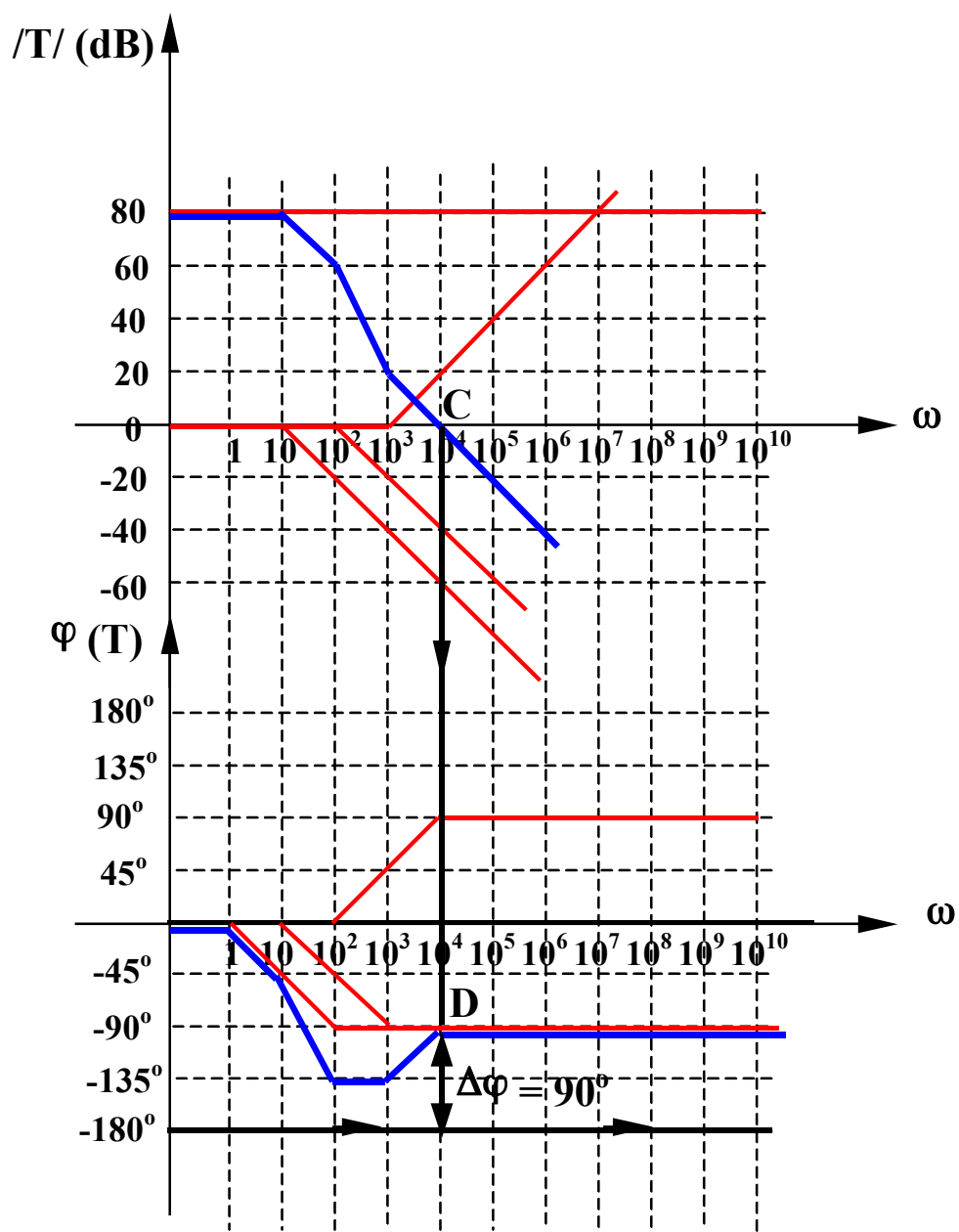

Linia orizontala la -180° nu intersecteaza diagrama de faza, deci circuitul este stabil.

7.4.3. Exemple

Exemplul 2. Evaluati stabilitatea urmatorului circuit

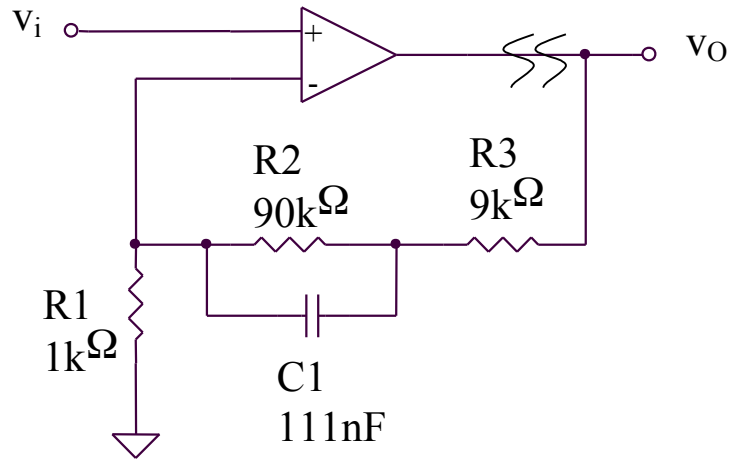

$$a(j\omega) = \frac{10^5}{\left(1 + j\frac{\omega}{10}\right)\left(1 + j\frac{\omega}{10^5}\right)^2}$$

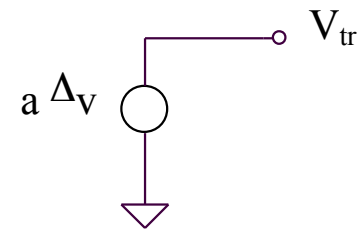
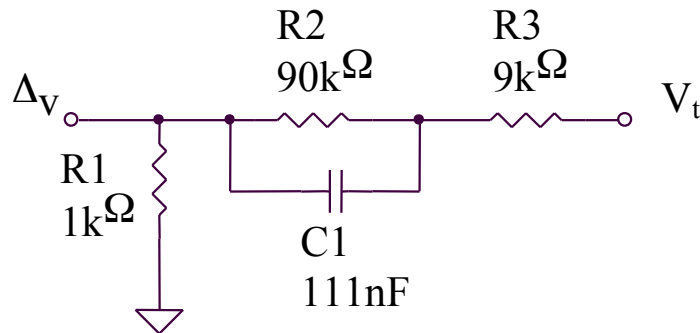

7.4.3. Exemple

Exemplul 2. Evaluati stabilitatea urmatorului circuit

$$T = \frac{V_{tr}}{V_t} = \frac{a\Delta v}{V_t} = a \frac{R_1}{R_1 + R_3 + R_2 // X_{C1}}$$

$$T = a \frac{R_1}{R_1 + R_3 + \frac{R_2}{1 + j\omega C_1 R_2}} = a \frac{R_1}{R_1 + R_2 + R_3} \frac{1 + j\omega C_1 R_2}{1 + j\omega C_1 [R_2 // (R_1 + R_3)]}$$

$$T = 10^3 \frac{1 + j \frac{\omega}{10^2}}{\left(1 + j \frac{\omega}{10}\right) \left(1 + j \frac{\omega}{10^3}\right) \left(1 + j \frac{\omega}{10^5}\right)^2}$$

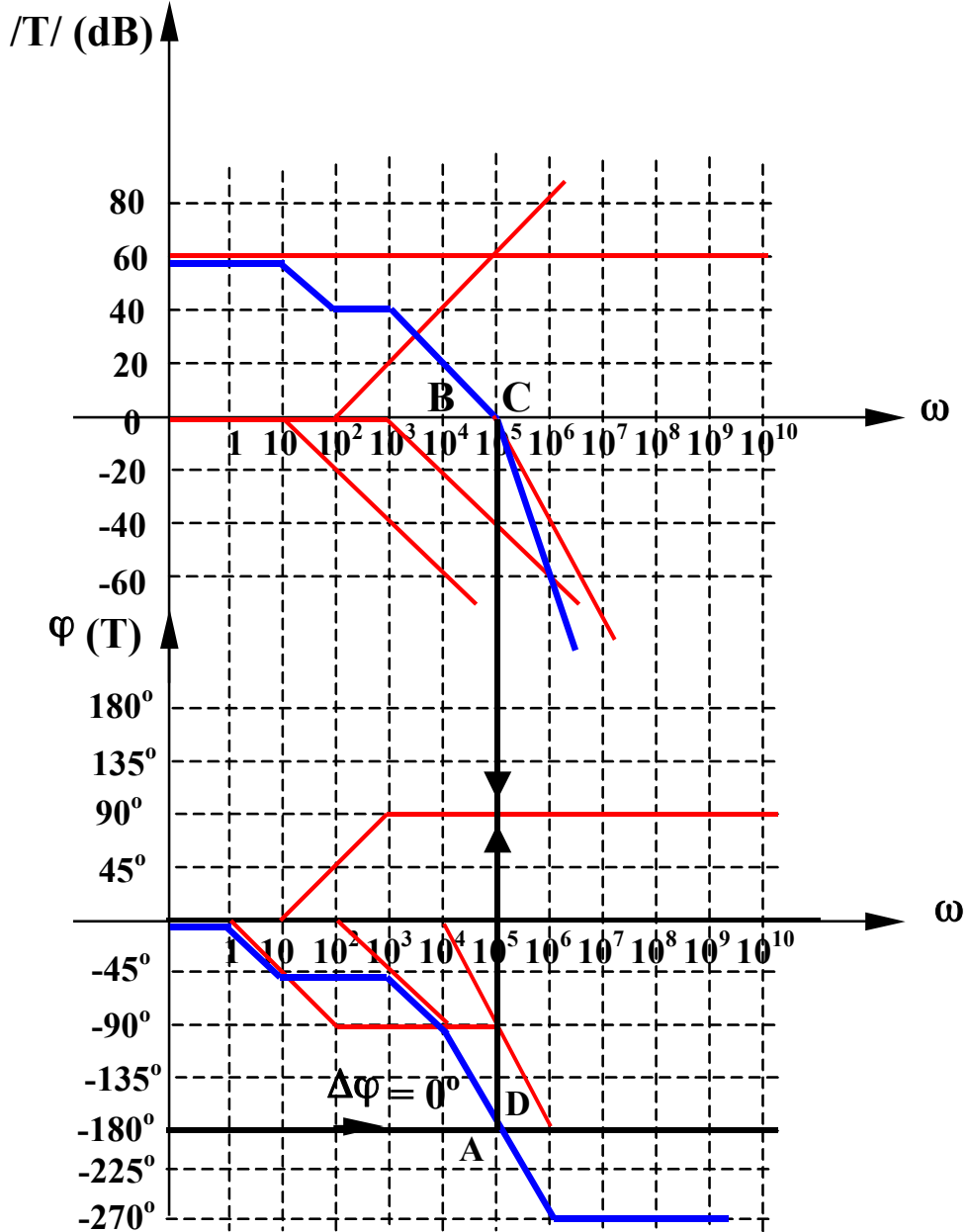

Linia orizontala la -180° intersecteaza diagrama de faza in A, $/T_B/ = 0$, deci circuitul este la limita de stabilitate ($\Delta\varphi = 0$).

7.5. Compensarea in frecventa a amplificatoarelor operationale

7.5. Compensarea in frecventa a amplificatoarelor operationale

Compensarea presupune imbunatatirea raspunsului in frecventa al unui sistem format din amplificator si retea de reactie, in vederea evitarii oscilatiilor.

Circuitul compensat trebuie sa ramana stabil pentru o plaja larga de variatie a capacitatii de sarcina.

Compensarea cu condensator Miller pe etajul al doilea de amplificare al unui AO

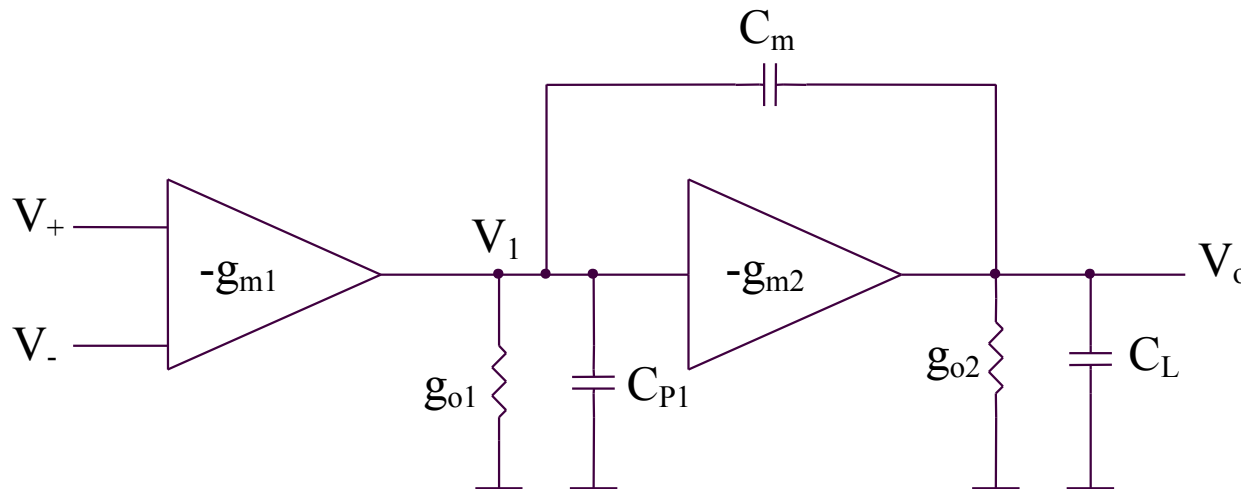

7.5. Compensarea in frecventa a amplificatoarelor operationale

Compensarea cu condensator Miller pe etajul al doilea de amplificare al unui AO

$$\begin{aligned}V_1(sC_{P1} + sC_m + g_{O1}) &= V_O sC_m - g_{m1}(V_+ - V_-) \\V_O(sC_m + sC_L + g_{O2}) &= V_1 sC_m - g_{m2}V_1\end{aligned}$$

Rezulta:

$$a(s) = \frac{V_O}{V_+ - V_-} = \frac{g_{m1}R_{O1}g_{m2}R_{O2} \left(1 - s \frac{C_m}{g_{m2}}\right)}{1 + a_1s + a_2s^2}$$

unde:

$$\begin{aligned}a_1 &= (C_m + C_L)R_{O2} + (C_{P1} + C_m)R_{O1} + g_{m2}C_mR_{O1}R_{O2} \\a_2 &= (C_mC_{P1} + C_LC_{P1} + C_mC_L)R_{O1}R_{O2}\end{aligned}$$

7.5. Compensarea in frecventa a amplificatoarelor operationale

Compensarea cu condensator Miller pe etajul al doilea de amplificare al unui AO

$$a(s) = a_O \frac{1 - \frac{s}{\omega_Z}}{\left(1 + \frac{s}{\omega_{P1}'}\right) \left(1 + \frac{s}{\omega_{P2}'}\right)} \quad a_O = g_{m1}R_{O1}g_{m2}R_{O2}$$

$$\omega_Z = \frac{g_{m2}}{C_m}$$

Considerand $\omega_{P1}' \ll \omega_{P2}'$, se obtine:

$$\omega_{p1}' \cong \frac{1}{a_1} = \frac{1}{(C_m + C_L)R_{O2} + (C_{P1} + C_m)R_{O1} + g_{m2}C_m R_{O1}R_{O2}}$$

$$\omega_{p1}' \cong \frac{1}{C_m g_{m2} R_{O1} R_{O2}} = \frac{\omega_{p1} C_{P1}}{a_2 C_m} \quad \omega_{p1} = \frac{1}{R_{O1} C_{P1}}$$

$$\omega_{p2}' \cong \frac{a_1}{a_2} = \frac{(C_m + C_L)R_{O2} + (C_{P1} + C_m)R_{O1} + g_{m2}C_m R_{O1}R_{O2}}{(C_m C_{P1} + C_L C_{P1} + C_m C_L)R_{O1}R_{O2}}$$

$$\omega_{p2}' \cong \frac{g_{m2}}{C_{P1} + C_L + \frac{C_{P1}C_L}{C_m}} = \frac{\omega_{p2} a_2}{1 + \frac{C_{P1}}{C_m} + \frac{C_{P1}}{C_L}} \quad \omega_{P2} = \frac{1}{R_{O2} C_L}$$

7.5. Compensarea in frecventa a amplificatoarelor operationale

Compensarea cu condensator Miller pe etajul al doilea de amplificare al unui AO

ω_{p1}' , ω_{p2}' – cu condensator de compensare C_m
 ω_{p1} , ω_{p2} – fara condensator de compensare C_m

Cand C_m creste, ω_{p1}' scade si ω_{p2}' creste, indepartandu-se unul de celalalt (pole splitting) si validand, astfel, presupunerea $\omega_{p1}' \ll \omega_{p2}'$.

7.5. Compensarea in frecventa a amplificatoarelor operationale

Compensarea cu condensator Miller pe etajul al doilea de amplificare al unui AO

