

# **Capitolul 4**

## **Amplificatoare elementare**

## **4.1. Etaje de amplificare cu un tranzistor**

### 4.1.1. Etajul sursa comuna

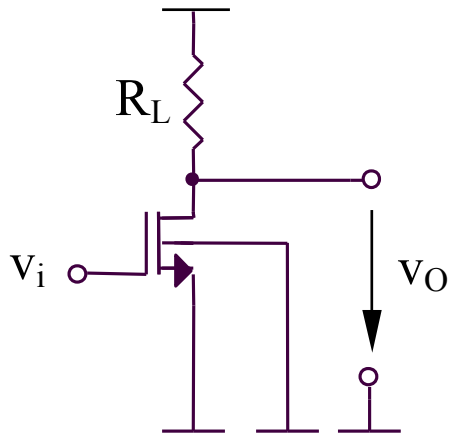

$$A_v = \frac{v_O}{v_I} = \frac{-g_m v_{GS} (R_L // r_{ds})}{v_{GS}}$$

$$A_v = -g_m (R_L // r_{ds})$$

$$R_i = \infty$$

$$R_o = R_L // r_{ds}$$

## 4.1.2. Etajul drena comuna

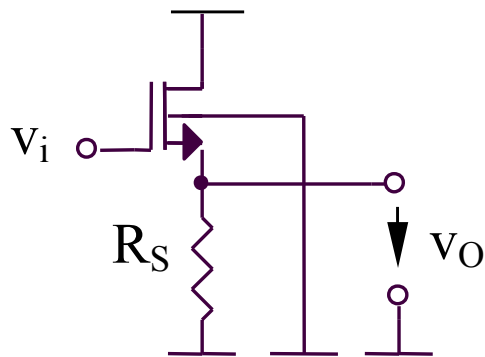

$$A_v = \frac{v_O}{v_I} = \frac{g_m v_{GS} R_S}{v_{GS} + g_m v_{GS} R_S}$$

$$A_v = \frac{g_m R_S}{1 + g_m R_S} \cong 1$$

$$R_i = \infty$$

$$R_o = \frac{1}{g_m} \parallel R_S$$

### 4.1.3. Etajul grila comuna

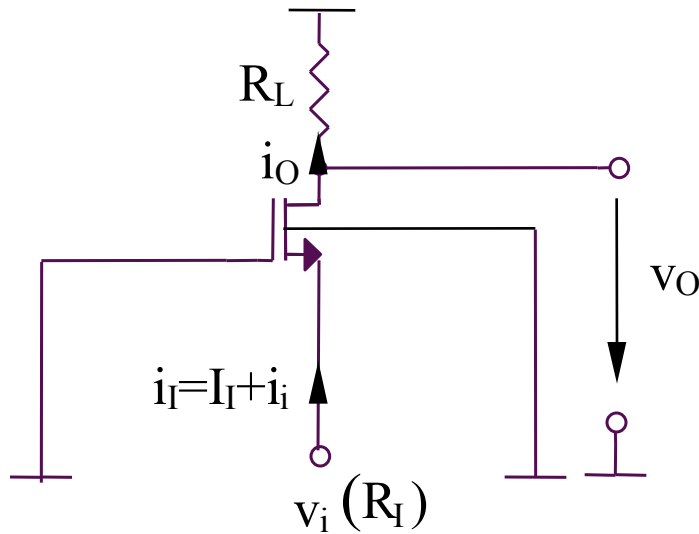

$$A_V = \frac{v_O}{v_I} = \frac{-g_m v_{GS} R_L}{-v_{GS}}$$

$$A_V = g_m R_L$$

$$R_i = \frac{1}{g_m}$$

$$R_o = R_L // r_{ds} (1 + g_m R_I)$$

### 4.1.4. Etajul sarcina distribuita (MOS)

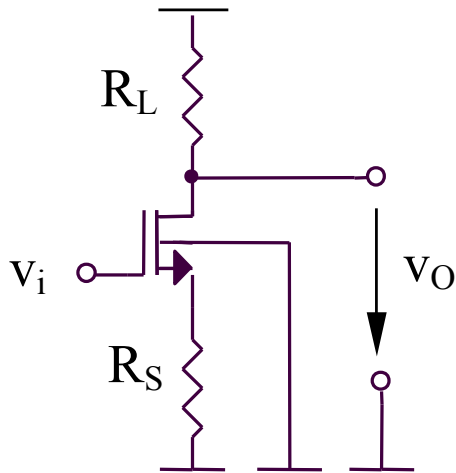

$$A_v = \frac{v_O}{v_I} = \frac{-g_m v_{GS} R_L}{v_{GS} + g_m v_{GS} R_S}$$

$$A_v = -\frac{g_m R_L}{1 + g_m R_S}$$

$$R_i = \infty$$

$$R_o = R_L // r_{ds} (1 + g_m R_S)$$

## 4.1.5. Etajul emitor comun

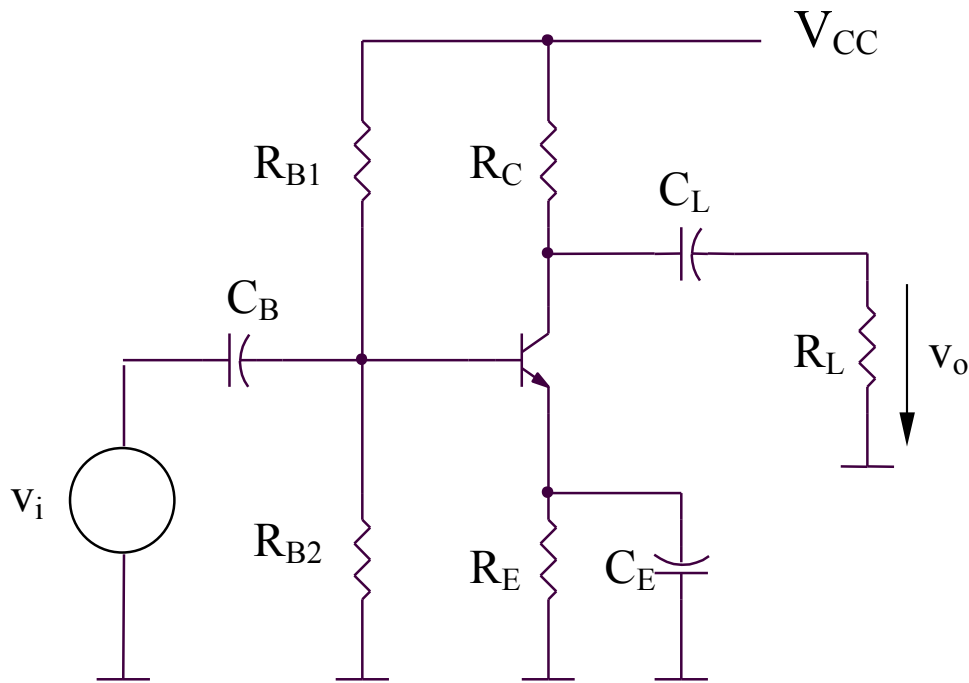

$$A_V = -g_m (R_C // R_L)$$

$$R_i = r_{\pi} // R_{B1} // R_{B2}$$

$$R_o = R_L // R_C // r_o$$

## 4.1.6. Etajul colector comun

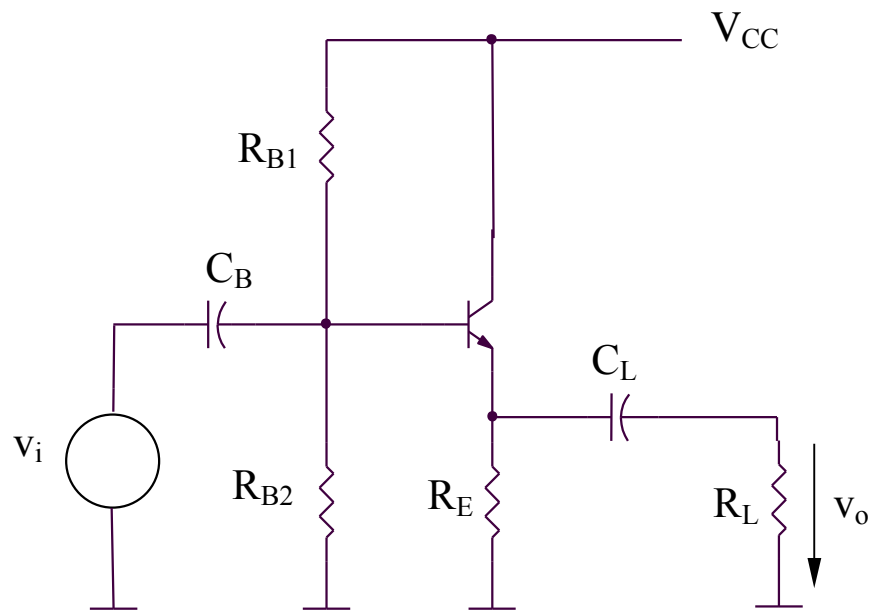

$$A_V = \frac{(\beta + 1)(R_E // R_L)}{r_\pi + (\beta + 1)(R_E // R_L)}$$

$$R_i = R_{B1} // R_{B2} // [r_\pi + (\beta + 1)(R_E // R_L)]$$

$$R_o = R_E // R_L // 1/g_m$$



## 4.1.7. Etajul baza comuna

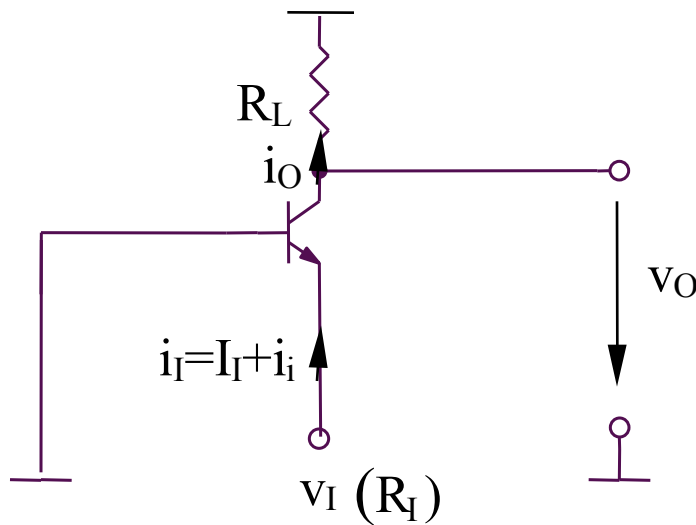

$$A_i = \frac{i_O}{i_I} \cong 1$$

$$A_V = \frac{v_O}{v_i} = g_m R_L$$

$$R_i = \frac{1}{g_m}$$

$$R_o = R_L // r_o \left( 1 + \frac{\beta R_I}{r_{\pi} + R_I} \right)$$

### 4.1.8. Etajul sarcina distribuita (bipolar)

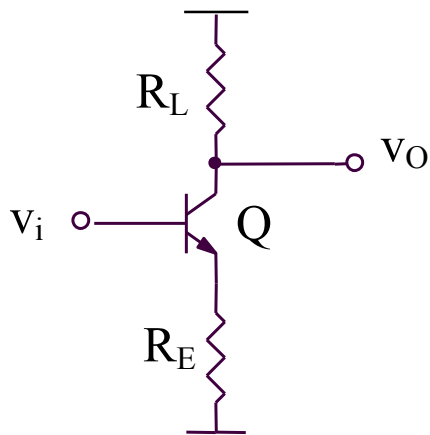

$$A_V = \frac{v_O}{v_i} = \frac{v_O}{i_C} \frac{i_C}{i_B} \frac{i_B}{v_i}$$

$$A_V = - \frac{\beta R_L}{r_\pi + (\beta + 1) R_E}$$

$$R_i = r_\pi + (\beta + 1) R_E$$

$$R_o = R_L // r_o \left( 1 + \frac{\beta R_E}{r_\pi + R_E} \right)$$

## **4.2. Amplificatorul cascod**

Avantajul amplificatorului cascod: raspuns in frecventa superior etajului emitor comun.

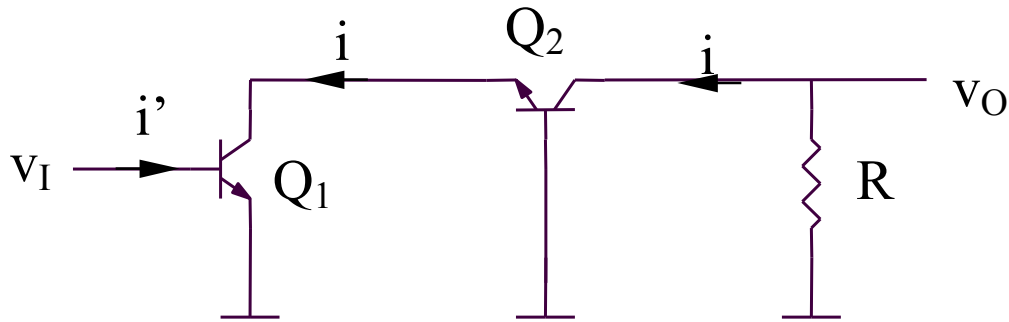

$$A_V = \frac{v_O}{v_I} = \frac{v_O}{i} \frac{i}{i'} \frac{i'}{v_I} = -R\beta \frac{1}{r_{\pi 1}} = -g_{m1}R$$

## **4.3. Amplificatoare diferentiale CMOS elementare**

## 4.3.1. Amplificatorul diferential CMOS cu sarcina pasiva

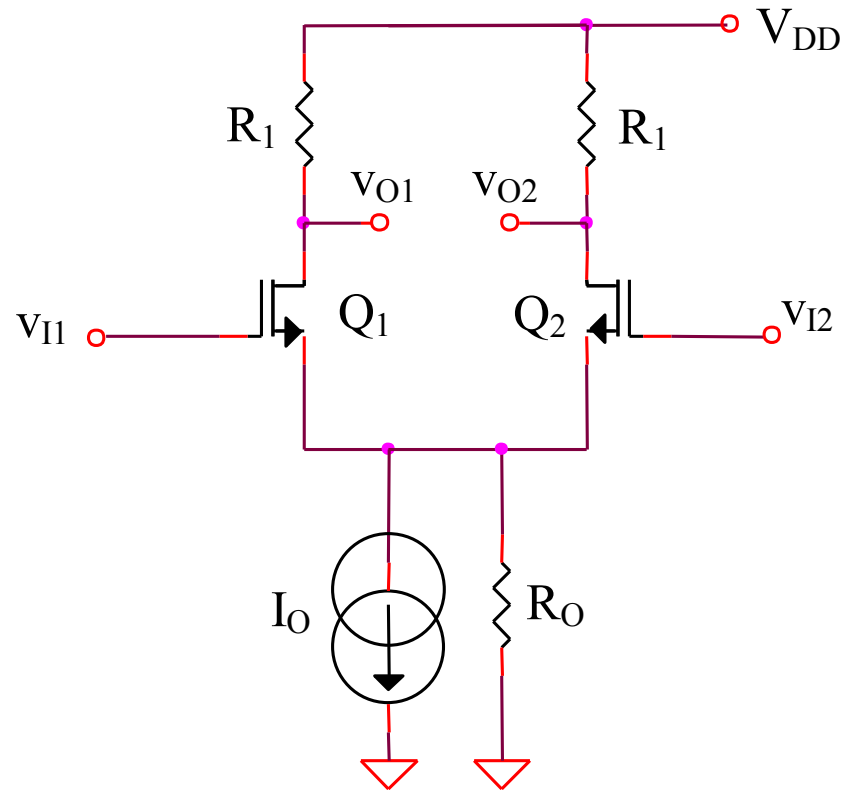

## **Amplificatorul diferential**

- reprezinta un bloc fundamental in proiectarea circuitelor integrate analogice
- caracteristicile tranzistoarelor trebuie sa fie identice
- aceeasi temperatura de functionare a tranzistoarelor
- rezistentele de sarcina de valoare egala

Tensiunea de iesire poate fi:

- diferentiala (simetrica):

$$v_O = v_{O1} - v_{O2}$$

- asimetrica:

$$v_O = v_{O1} \text{ sau } v_{O2}$$

## Analiza de semnal mare

$$v_{I1} - v_{I2} = v_{GS1} - v_{GS2} = \left( V_T + \sqrt{\frac{2i_{D1}}{K}} \right) - \left( V_T + \sqrt{\frac{2i_{D2}}{K}} \right) = \sqrt{\frac{2}{K}} (\sqrt{i_{D1}} - \sqrt{i_{D2}})$$

$$i_{D1} + i_{D2} = I_O$$

$$v_I = v_{I1} - v_{I2}$$

$$\Rightarrow i_{D1}^2 - I_O i_{D1} + \frac{1}{4} \left( I_O - \frac{K v_I^2}{2} \right)^2 = 0$$

Deci:

$$i_{D1} = \frac{I_O}{2} + \frac{I_O}{2} \sqrt{\frac{K v_I^2}{I_O} - \frac{K^2 v_I^4}{4 I_O^2}} \quad i_{D2} = \frac{I_O}{2} - \frac{I_O}{2} \sqrt{\frac{K v_I^2}{I_O} - \frac{K^2 v_I^4}{4 I_O^2}}$$

pentru  $v_I = \sqrt{\frac{2I_O}{K}}$  rezulta  $i_{D1} = I_O$ ,  $i_{D2} = 0$

Tensiunea de iesire este (pentru iesire diferentiala):

$$v_O = R_1 (i_{D2} - i_{D1})$$

$$v_O = -I_O R_1 \sqrt{\frac{K v_I^2}{I_O} - \frac{K^2 v_I^4}{4 I_O^2}} = -\frac{R_1 v_I}{2} \sqrt{4 K I_O - K^2 v_I^2}$$



Dezvoltarea in serie Taylor a expresiei tensiunii de iesire este:

$$v_O(v_I) = -K^{1/2} I_O^{1/2} R_1 v_I + \frac{K^{3/2} R_1}{8 I_O^{1/2}} v_I^3 + \frac{K^{5/2} R_1}{128 I_O^{3/2}} v_I^5 + \dots$$

$$v_O(v_I) = a_1 v_I + a_3 v_I^3 + a_5 v_I^5 + \dots$$

Amplificarea de mod diferential:

$$A_{dd} = a_1 = -R_1 \sqrt{K I_O}$$

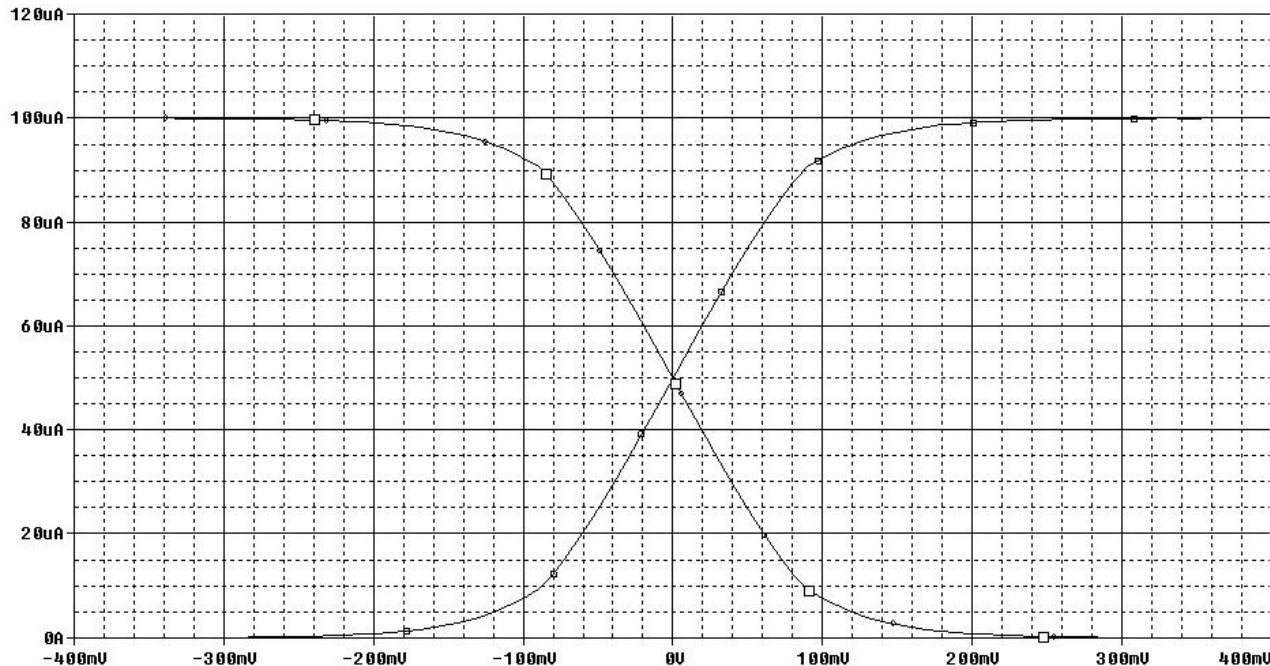

Caracteristicile  $i_{D1}, i_{D2}(v_I)$

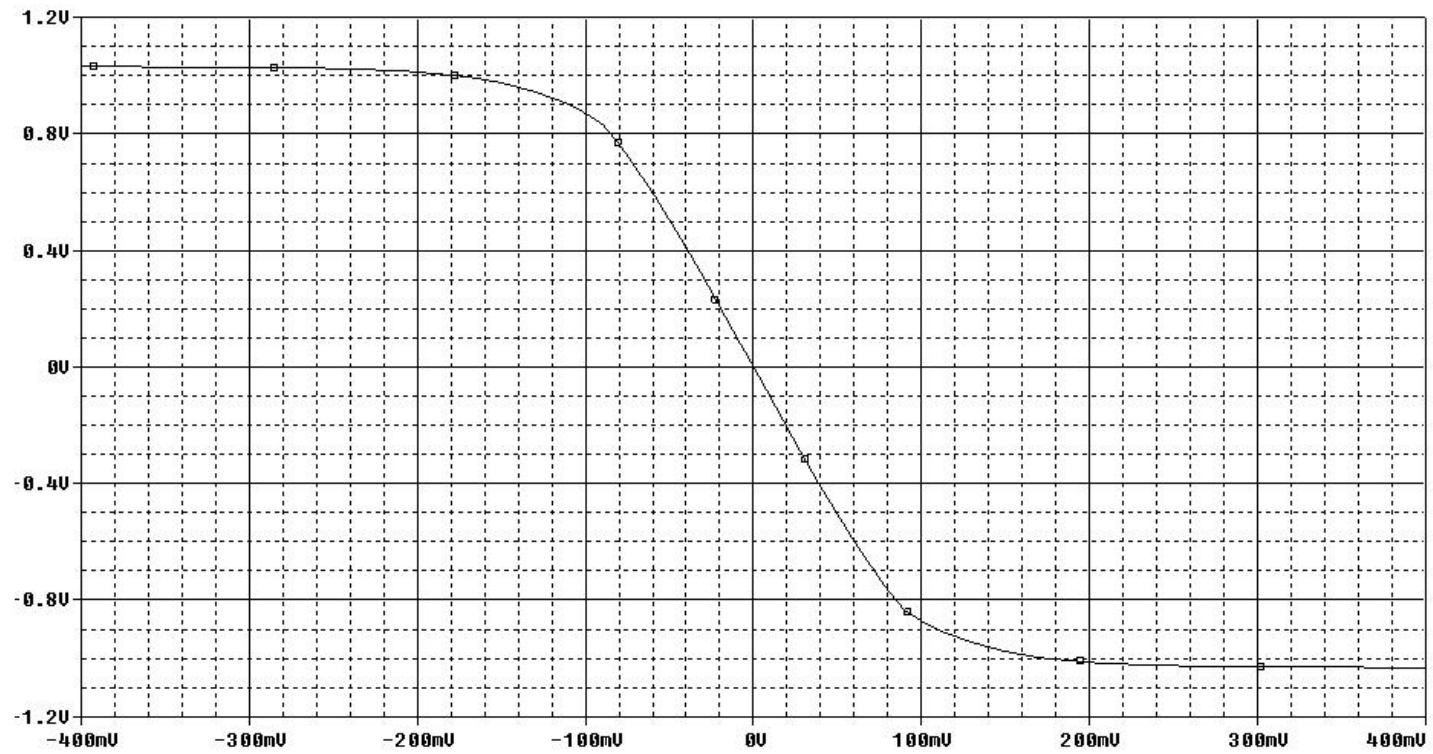

Caratteristica  $v_O(v_I)$

## Analiza de semnal mic

Tensiuni de mod diferential:  $v_{id}$ ,  $v_{od}$

Tensiuni de mod comun:  $v_{ic}$ ,  $v_{oc}$

$v_{id} = v_{i1} - v_{i2}$  - tensiunea diferentiala de intrare

$v_{od} = v_{o1} - v_{o2}$  - tensiunea diferentiala de iesire

$v_{ic} = \frac{v_{i1} + v_{i2}}{2}$  - tensiunea de mod comun de intrare

$v_{oc} = \frac{v_{o1} + v_{o2}}{2}$  - tensiunea de mod comun de iesire

$$\Rightarrow v_{i1} = v_{ic} + \frac{v_{id}}{2} \quad ; \quad v_{o1} = v_{oc} + \frac{v_{od}}{2}$$

$$v_{i2} = v_{ic} - \frac{v_{id}}{2} \quad ; \quad v_{o2} = v_{oc} - \frac{v_{od}}{2}$$

## Amplificarile in tensiune

$$A_{dd} = \left. \frac{v_{od}}{v_{id}} \right|_{v_{ic}=0} \quad - \text{amplificare de mod diferential}$$

$$A_{cc} = \left. \frac{v_{oc}}{v_{ic}} \right|_{v_{id}=0} \quad - \text{amplificare de mod comun}$$

$$A_{cd} = \left. \frac{v_{od}}{v_{ic}} \right|_{v_{id}=0} \quad - \text{amplificare mod comun - mod diferential}$$

$$A_{dc} = \left. \frac{v_{oc}}{v_{id}} \right|_{v_{ic}=0} \quad - \text{amplificare mod diferential - mod comun}$$

Tensiunile de iesire (diferentiala si de mod comun) vor avea expresiile:

$$v_{od} = A_{dd}v_{id} + A_{cd}v_{ic}$$

$$v_{oc} = A_{dc}v_{id} + A_{cc}v_{ic}$$

Rezulta:

$$v_{o1} = \left( A_{dc} + \frac{A_{dd}}{2} \right) v_{id} + \left( A_{cc} + \frac{A_{cd}}{2} \right) v_{ic}$$

$$v_{o2} = \left( A_{dc} - \frac{A_{dd}}{2} \right) v_{id} + \left( A_{cc} - \frac{A_{cd}}{2} \right) v_{ic}$$

Pentru un amplificator diferential perfect simetric,  $A_{dc} = 0$  si  $A_{cd} = 0$ , deci:

$$v_{o1} = \frac{A_{dd}}{2} v_{id} + A_{cc} v_{ic}$$

$$v_{o2} = -\frac{A_{dd}}{2} v_{id} + A_{cc} v_{ic}$$

Raportul de rejectie a modului comun (CMRR = Common-Mode Rejection Ratio) este:

$$CMRR = \frac{|A_{dm}|}{|A_{cm}|} = \frac{\left| \frac{v_o}{v_{id}} \right|}{\left| \frac{v_o}{v_{ic}} \right|}$$

$A_{dm}$  si  $A_{cm}$  sunt diferite pentru iesire diferentiala ( $v_o = v_{od}$ ), respectiv simpla ( $v_o = v_{o1}$  sau  $v_{o2}$ ).

## Determinarea amplificărilor de semnal mic: metoda semicircuitului

**Mod diferential** ( $v_{id} \neq 0$ ,  $v_{ic} = 0 \Rightarrow v_{i1} = v_{id}$ ,  $v_{i2} = -v_{id}$ )

S-a introdus o rezistență de sarcină suplimentară ( $R_L$ ).

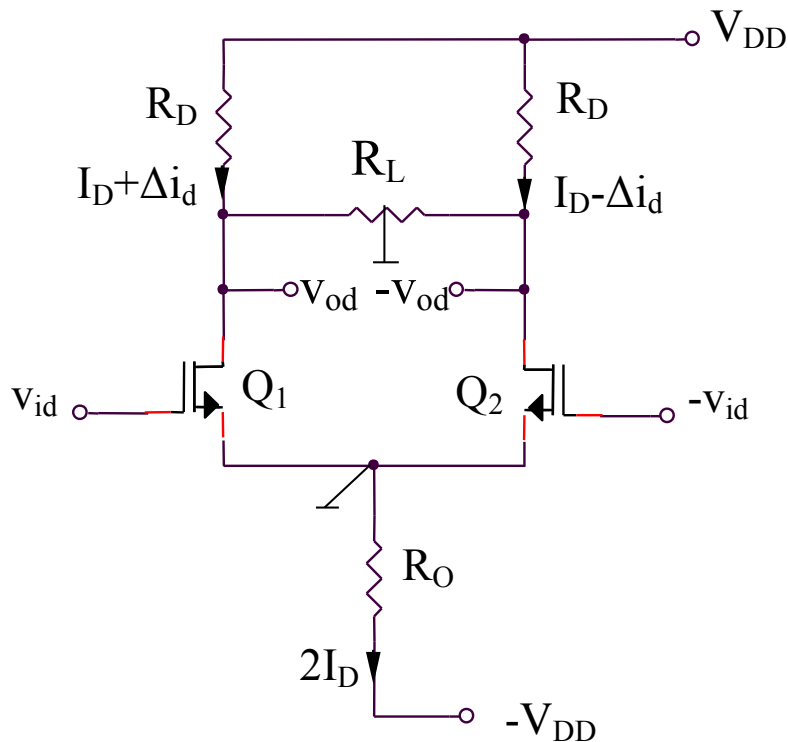

(a)

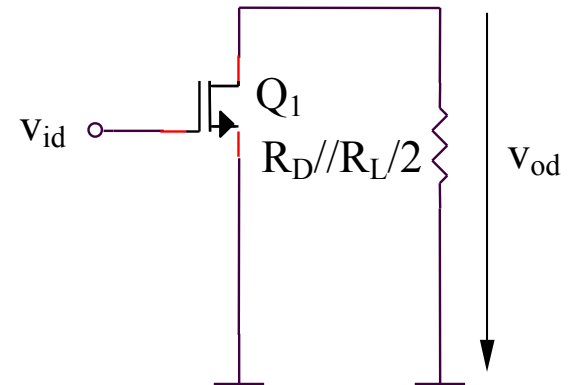

(b)

Amplificarea in tensiune de mod diferential:

$$A_{dd} = \frac{v_{od}}{v_{id}} = -g_{m1} \left( R_D // \frac{R_L}{2} \right)$$

- iesire simetrica:

$$A = \frac{2v_{od}}{2v_{id}} = A_{dd}$$

- iesire asimetrica:

$$A = \frac{v_{od}}{2v_{id}} = \frac{A_{dd}}{2}$$

Rezistenta diferentiala de intrare:

$$R_{id} = \infty$$

**Mod comun (  $v_{ic} \neq 0$ ,  $v_{id} = 0 \Rightarrow v_{i1} = v_{ic}$ ,  $v_{i2} = v_{ic}$  )**

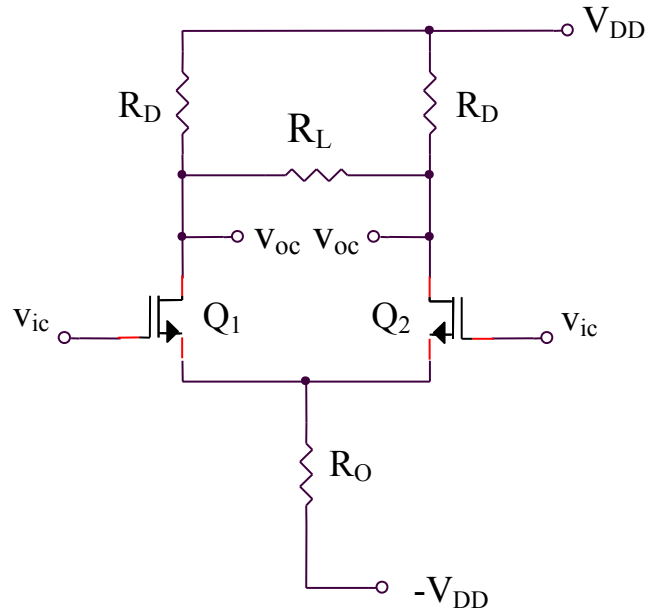

(a)

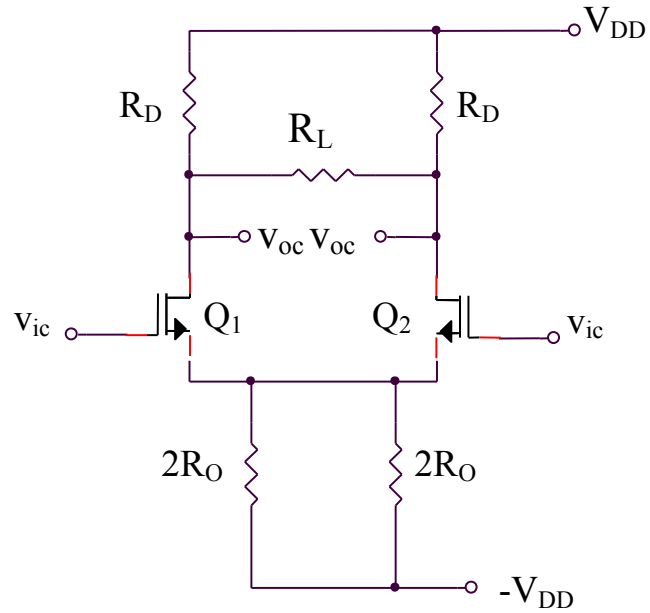

(b)

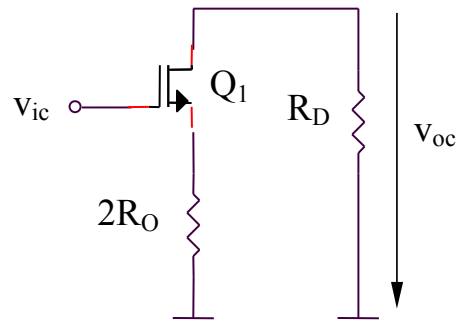

(c)



Amplificarea in tensiune de mod comun:

$$A_{cc} = \frac{v_{oc}}{v_{ic}} = -\frac{g_{m1}R_D}{1 + g_{m1}2R_O} \cong -\frac{R_D}{2R_O}$$

Rezistenta de intrare de mod comun:

$$R_{ic} = \infty$$

Deci:

$$CMRR = \frac{2g_{m1}R_L R_O}{2R_D + R_L}$$

Pentru cresterea CMRR, trebuie marita valoarea rezistentei  $R_O$ , prin inlocuirea Sursei de curent de polarizare printr-o sursa de curent de tip cascod.

# Domeniul maxim al tensiunii de intrare de mod comun

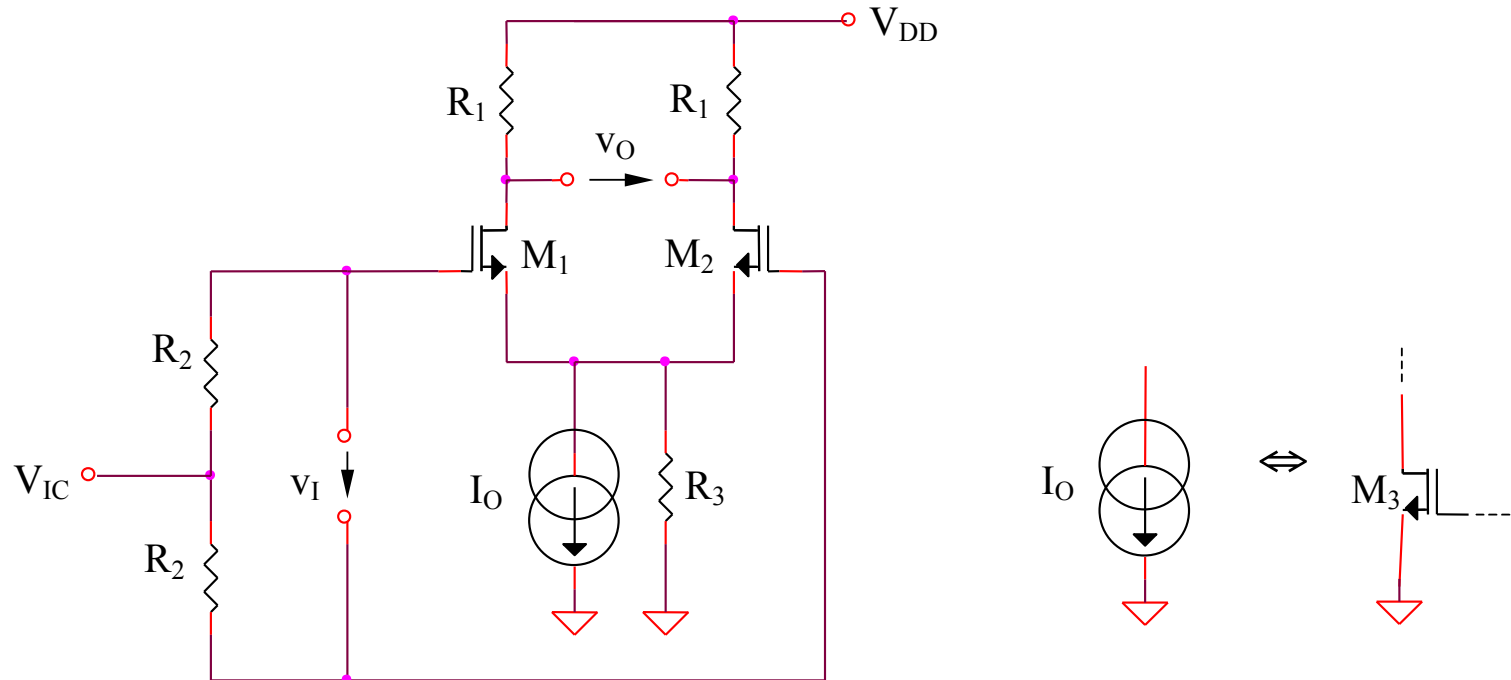

$$V_{IC}^{min} = v_{GS1} + v_{DS3sat} = v_{GS1} + v_{GS3} - V_T = V_T + (\sqrt{2} + 1) \sqrt{\frac{I_O}{K}}$$

$$V_{IC}^{max} = V_{DD} - \frac{I_O R_1}{2} - v_{DS1sat} + v_{GS1} = V_{DD} - \frac{I_O R_1}{2} + V_T$$

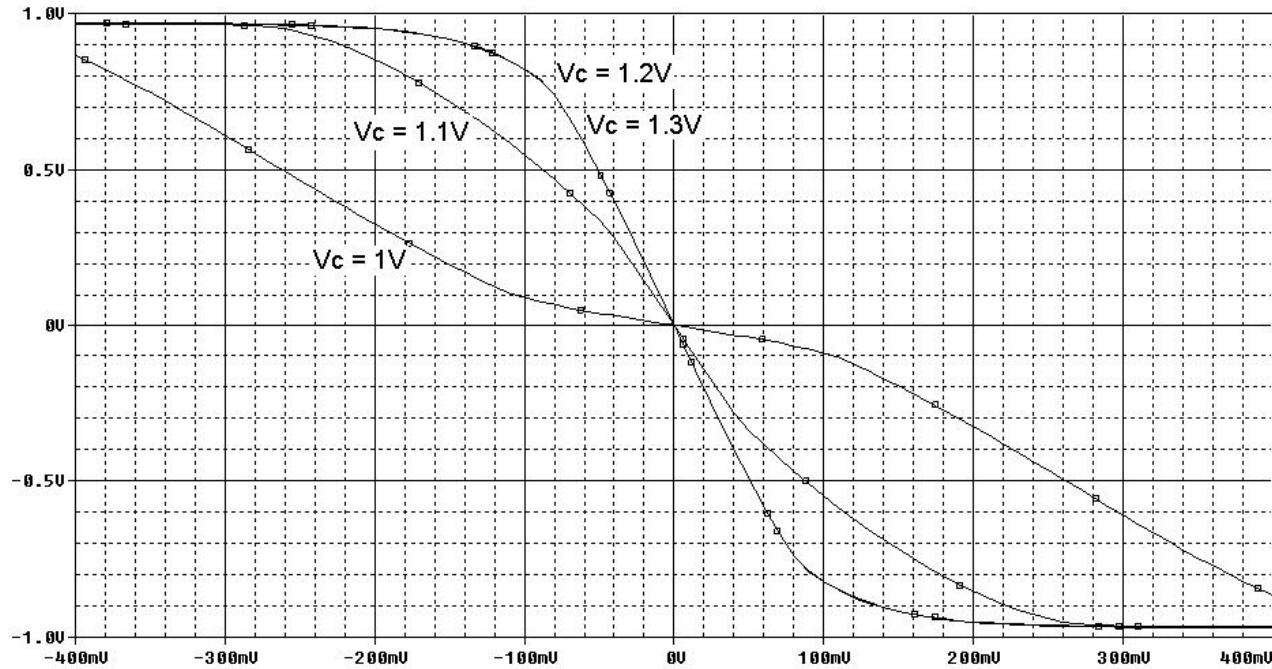

Caracteristicile  $v_O(v_I)$  pentru tensiuni de intrare de mod comun multiple

$$V_C^{min} = V_{IC}^{min} \cong 1,2V$$

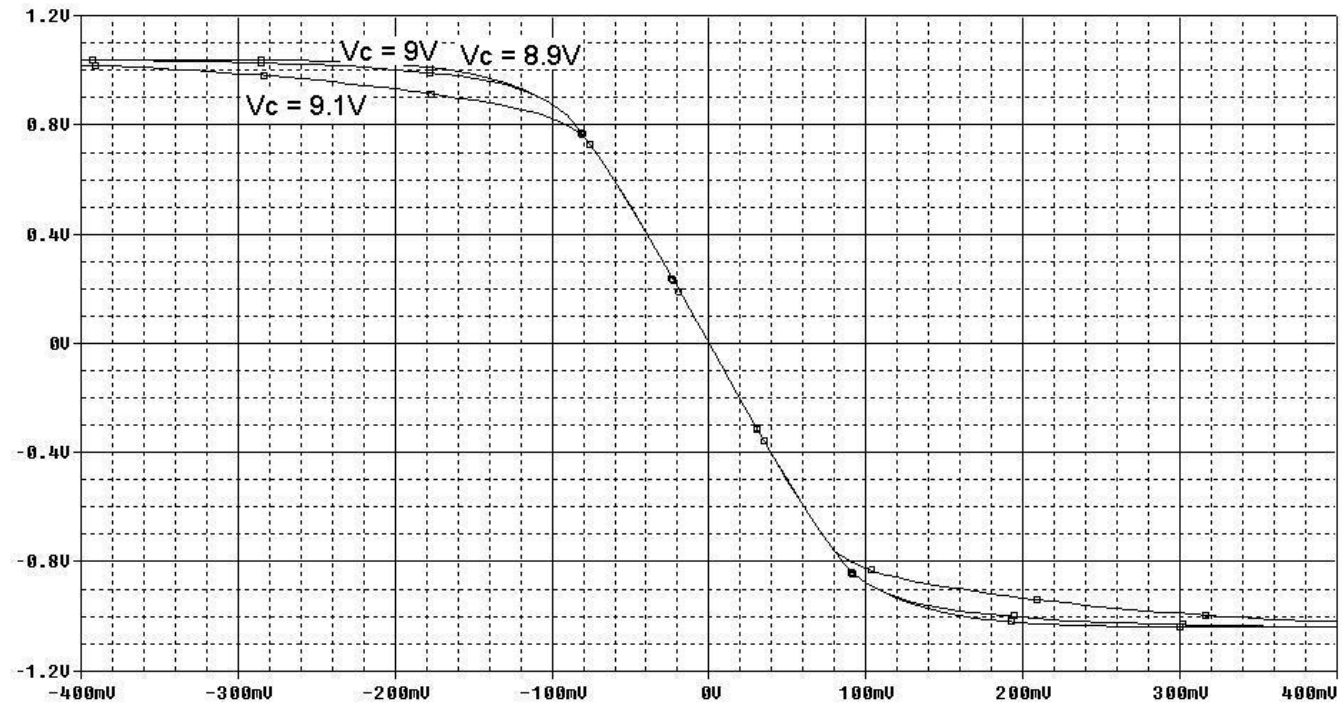

Caracteristicile  $v_O(v_I)$  pentru tensiuni de intrare de mod comun multiple

$$V_C^{max} = V_{IC}^{max} \cong 9V$$

Cresterea domeniului maxim al tensiunii de intrare de mod diferential asociat unei functionari liniare este posibila prin introducerea unor rezistente in sursele tranzistoarelor.

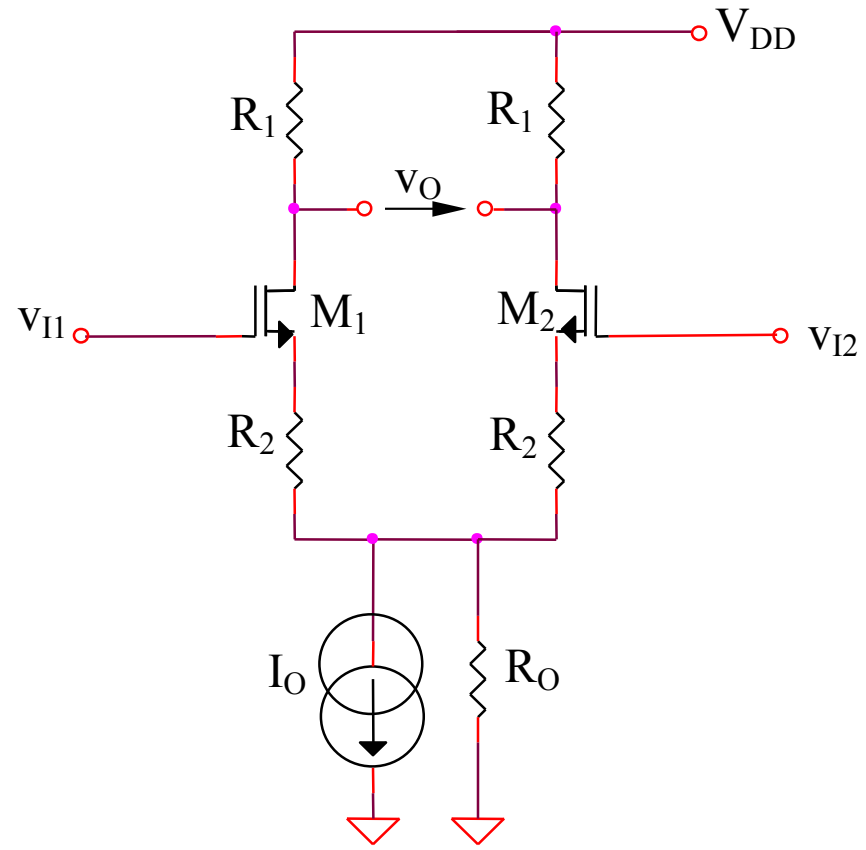

$$A_{dd} = -\frac{g_m R_1}{1 + g_m R_2}$$

$$A_{cc} = -\frac{g_m R_1}{1 + g_m (R_2 + 2R_O)}$$

$$V_{ICmin} = v_{GS1} + v_{DS3sat} + \frac{I_O R_2}{2} = v_{GS1} + v_{GS3} - V_T + \frac{I_O R_2}{2} = V_T + (\sqrt{2} + 1) \sqrt{\frac{I_O}{K}} + \frac{I_O R_2}{2}$$

$$V_{ICmax} = V_{DD} - \frac{I_O R_1}{2} - v_{DS1sat} + v_{GS1} = V_{DD} - \frac{I_O R_1}{2} + V_T$$

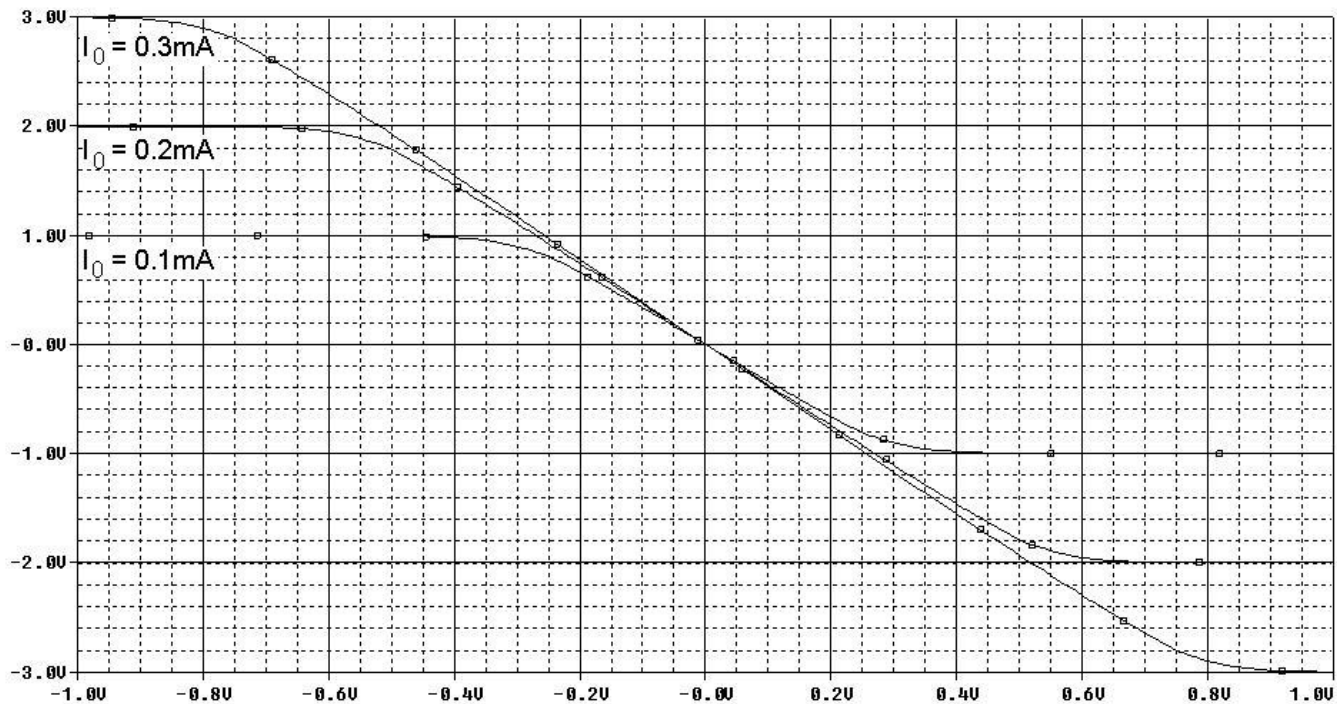

Caracteristicile  $v_O(v_I)$  pentru curenți de polarizare multipli

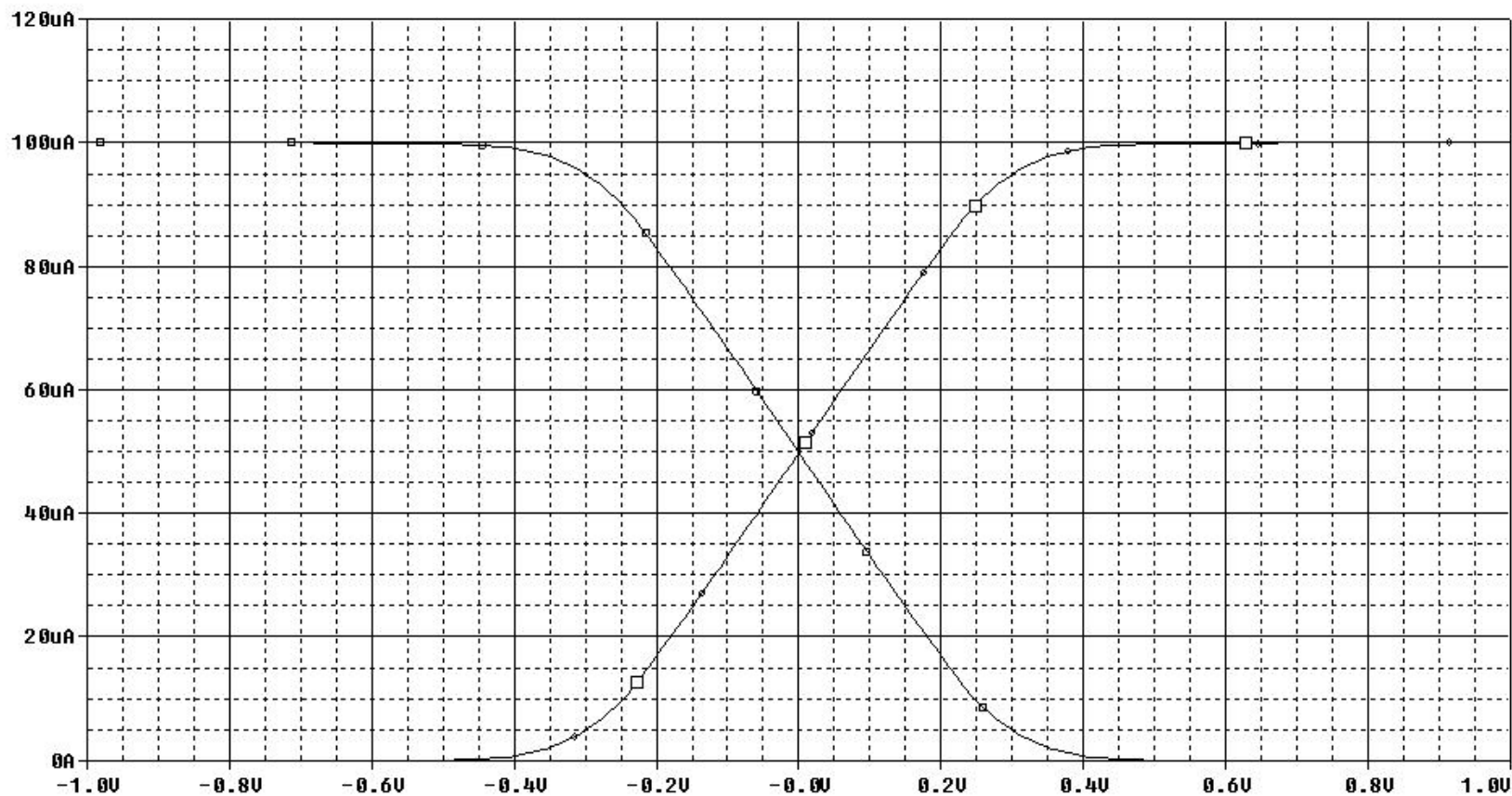

Caracteristicile  $i_{D1}, i_{D2}(v_I)$

**SIMULARI pentru amplificatorul diferential CMOS**  
**Analiza de mod diferential si semnal mare**



# SIMULARI pentru amplificatorul diferential CMOS

## Analiza de mod diferential si semnal mare

### SIM 4.1: $V_O$ (V2)

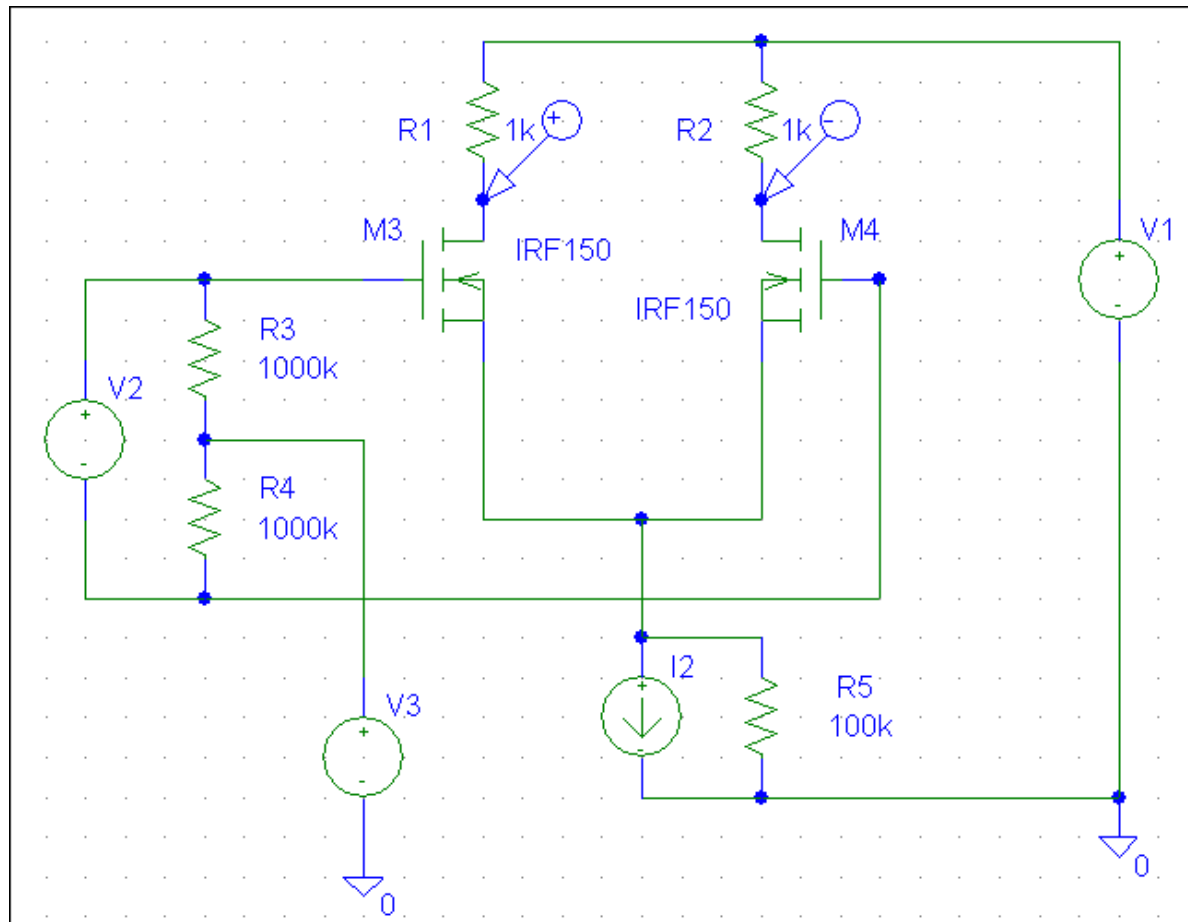

# SIMULARI pentru amplificatorul diferential CMOS

## Analiza de mod diferential si semnal mare

### SIM 4.2: $i_{D1}$ , $i_{D2}$ (V2)

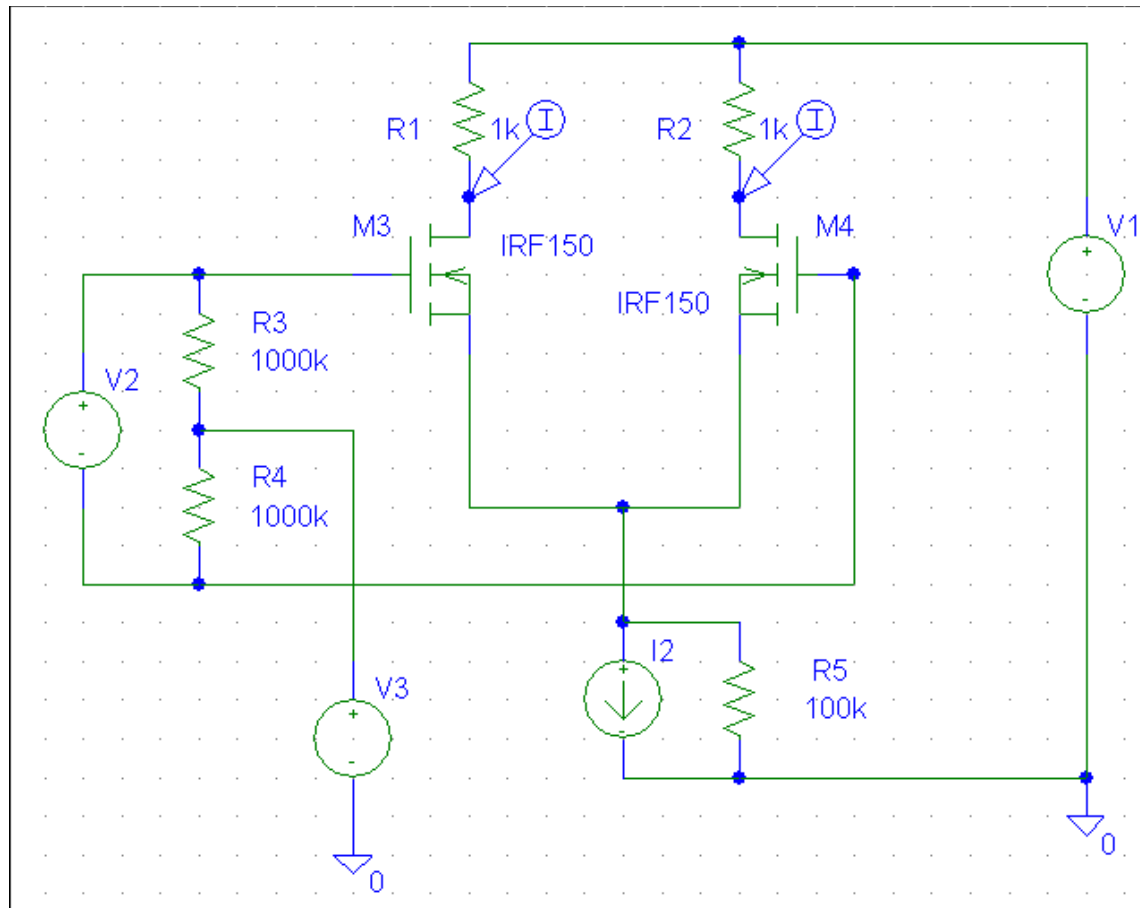

# SIMULARI pentru amplificatorul diferential CMOS

## Analiza de mod diferential si semnal mare

### SIM 4.3: $V_O$ (V2), I2 - parametru

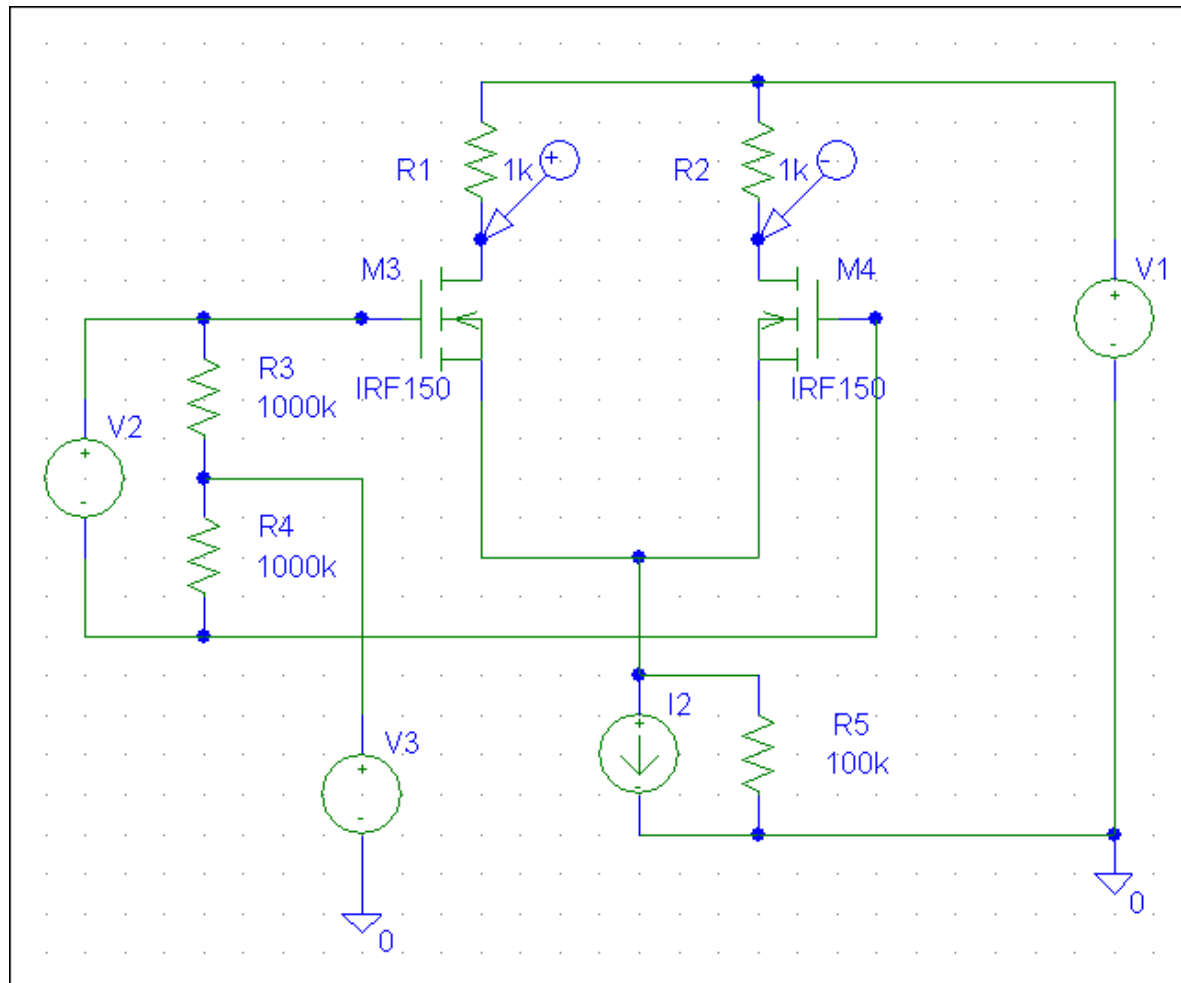

# SIMULARI pentru amplificatorul diferential CMOS

## Analiza de mod diferential si semnal mare

### SIM 4.4: $i_{D1}$ , $i_{D2}$ (V2), I2 - parametru

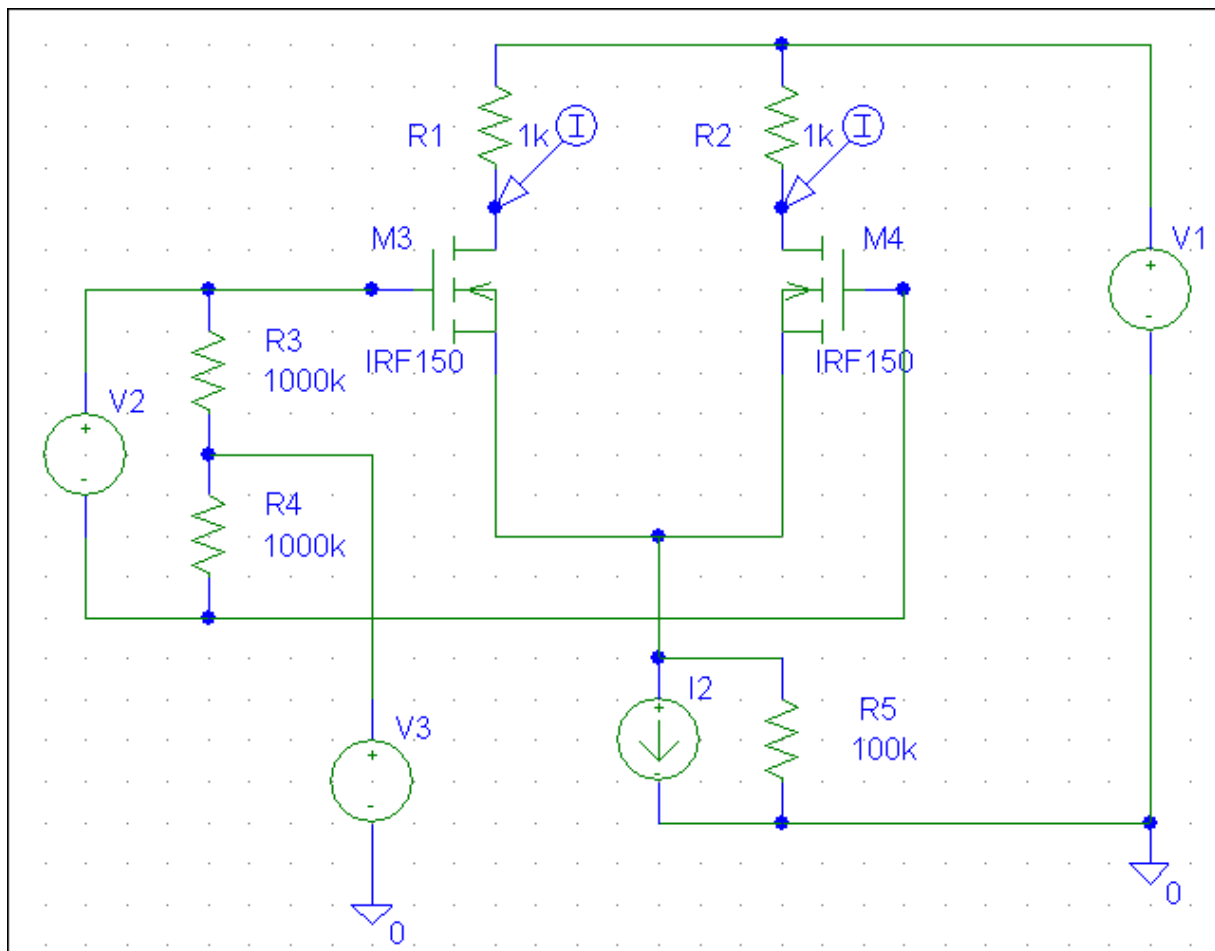

**SIMULARI pentru amplificatorul diferential CMOS**  
**Analiza de mod comun si semnal mare**

# SIMULARI pentru amplificatorul diferential CMOS

## Analiza de mod comun si semnal mare

### SIM 4.5: $V_{C1}$ (V2)

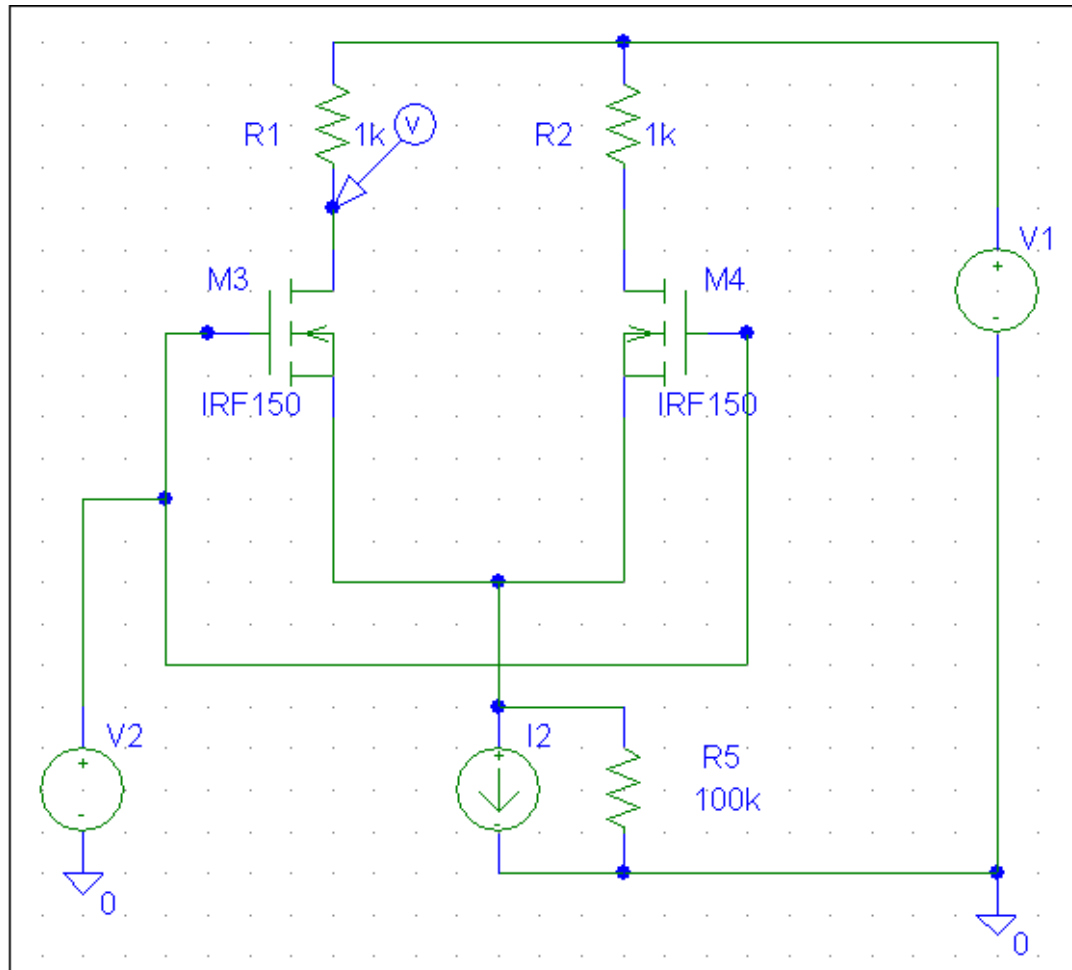

## Tensiunea de offset de intrare

Daca cele doua tranzistoare nu sunt identice, este necesara aplicarea unei tensiuni de intrare nenule (numita tensiune de offset de intrare) in vederea anularii tensiunii de iesire.

$$V_{IO} = v_{GS1} - v_{GS2} = (V_{T1} - V_{T2}) + \left( \sqrt{\frac{2i_{D1}}{K'(W/L)_1}} - \sqrt{\frac{2i_{D2}}{K'(W/L)_2}} \right)$$

$$V_{IO} = \Delta V_T + \sqrt{\frac{2(i_D + \Delta i_D / 2)}{K'[(W/L) - \Delta(W/L)/2]}} - \sqrt{\frac{2(i_D - \Delta i_D / 2)}{K'[(W/L) + \Delta(W/L)/2]}}$$

$$V_{IO} = \Delta V_T + \sqrt{\frac{2i_D}{K'(W/L)}} \left[ \sqrt{1 + \frac{\Delta i_D}{2i_D} + \frac{\Delta(W/L)}{2(W/L)}} - \sqrt{1 - \frac{\Delta i_D}{2i_D} - \frac{\Delta(W/L)}{2(W/L)}} \right]$$

Similar amplificatorului diferential bipolar, rezulta:

$$V_{IO} = \Delta V_T + \frac{V_{GS} - V_T}{2} \left[ \frac{\Delta i_D}{i_D} + \frac{\Delta(W/L)}{(W/L)} \right]$$

Dar:

$$\left( i_D + \frac{\Delta i_D}{2} \right) \left( R - \frac{\Delta R}{2} \right) = \left( i_D - \frac{\Delta i_D}{2} \right) \left( R + \frac{\Delta R}{2} \right)$$

echivalent cu:

$$\frac{\Delta i_D}{i_D} = \frac{\Delta R}{R}$$

Rezulta:

$$V_{IO} = \Delta V_T + \frac{V_{GS} - V_T}{2} \left[ \frac{\Delta R}{R} + \frac{\Delta(W/L)}{(W/L)} \right]$$



## 4.3.2. Amplificatorul diferential CMOS elementar cu sarcina activa

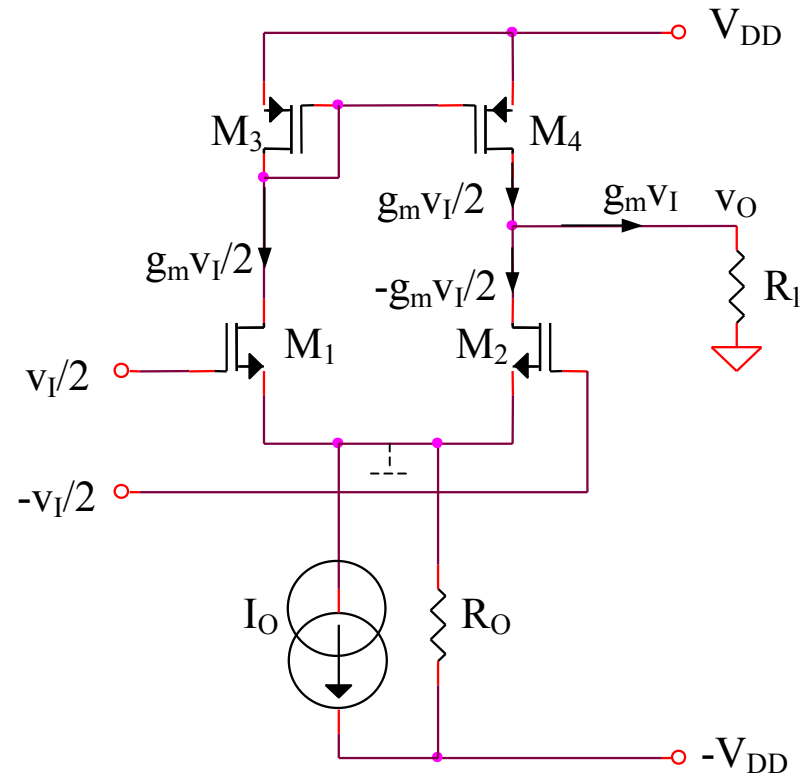

$$A_{dd} = g_m (r_{ds2} // r_{ds4} // R_l)$$

$$A_{dd} \Big|_{R_l \rightarrow \infty} = g_m (r_{ds2} // r_{ds4}) = g_m \frac{r_{ds}}{2} = \frac{1}{2\lambda} \sqrt{\frac{K}{I_O}}$$

## **4.4. Amplificatoare diferențiale bipolare elementare**

# 4.4.1. Amplificatorul diferential bipolar elementar cu sarcina pasiva

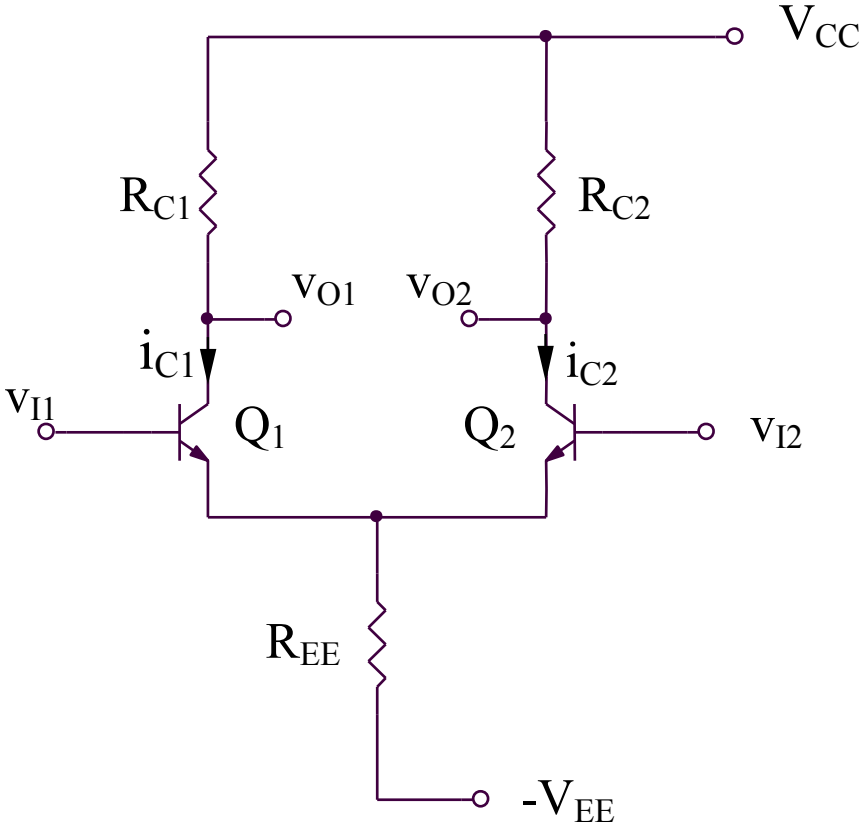

(a)

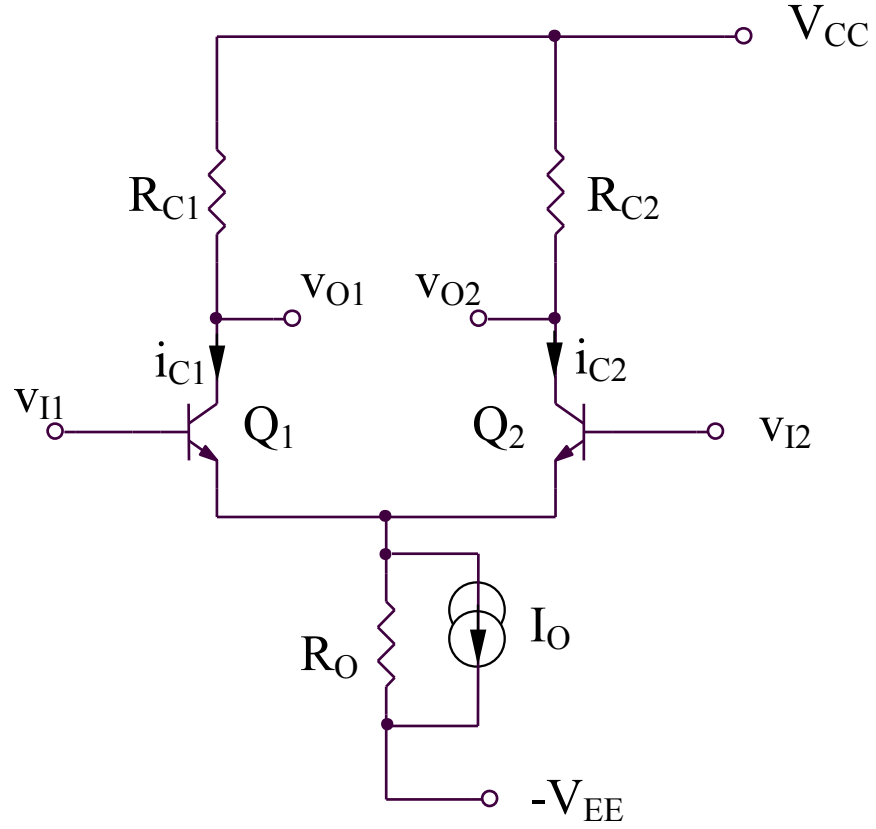

(b)

## Analiza de semnal mare

$$I_O = i_{E1} + i_{E2}$$

$$I_O = \frac{i_{C1} + i_{C2}}{\alpha}$$

Dar:

$$\alpha I_O = I_S \left( e^{\frac{v_{BE1}}{V_{th}}} + e^{\frac{v_{BE2}}{V_{th}}} \right)$$

$$\alpha I_O = I_S e^{\frac{v_{BE1}}{V_{th}}} \left( 1 + e^{\frac{v_{BE2} - v_{BE1}}{V_{th}}} \right)$$

$$i_{C1} = I_S e^{\frac{v_{BE1}}{V_{th}}}$$

$$v_{BE2} - v_{BE1} = v_{I2} - v_{I1}$$

Expresiile curenților de colector:

$$i_{C1} = \frac{\alpha I_O}{1 + e^{\frac{v_{I2} - v_{I1}}{V_{th}}}}$$

$$i_{C2} = \frac{\alpha I_O}{1 + e^{\frac{v_{I1} - v_{I2}}{V_{th}}}}$$

Expresiile  $i_{C1}$  si  $i_{C2}$  se pot dezvolta in serii Taylor:

$$\frac{i_{C1}(x)}{I_0} = \frac{1}{1+e^{-x}} = \frac{1}{2} + \frac{x}{4} - \frac{x^3}{48} + \dots \quad x = \frac{v_{I1} - v_{I2}}{V_{th}}$$

$$\frac{i_{C2}(x)}{I_0} = \frac{1}{1+e^x} = \frac{1}{2} - \frac{x}{4} + \frac{x^3}{48} - \dots \quad \alpha = 1$$

Deci, tangenta la caracteristica  $i_{C1}(x)/I_0$  are urmatoarea ecuatie:

$$y = \frac{1}{2} + \frac{x}{4}$$

Daca:

$$y = 0 \Rightarrow x = -2 \Rightarrow v_{I1} - v_{I2} = -2V_{th} = -50mV$$

### Remarci:

- pentru  $v_{I1} = v_{I2}$  (sau  $x = 0$ ),  $i_{C1} = i_{C2} = I_0/2$
- pentru o functionare aproximativ liniara, amplitudinea maxima a tensiunii de intrare trebuie sa fie mai mica decat  $2V_{th}$  ( $x = 2$ ), deci aproximativ 50mV

Caracteristicile statice  $(i_{C1}, i_{C2})/I_O = f [(v_{I1}-v_{I2})/V_{th}]$   
ale amplificatorului diferential bipolar

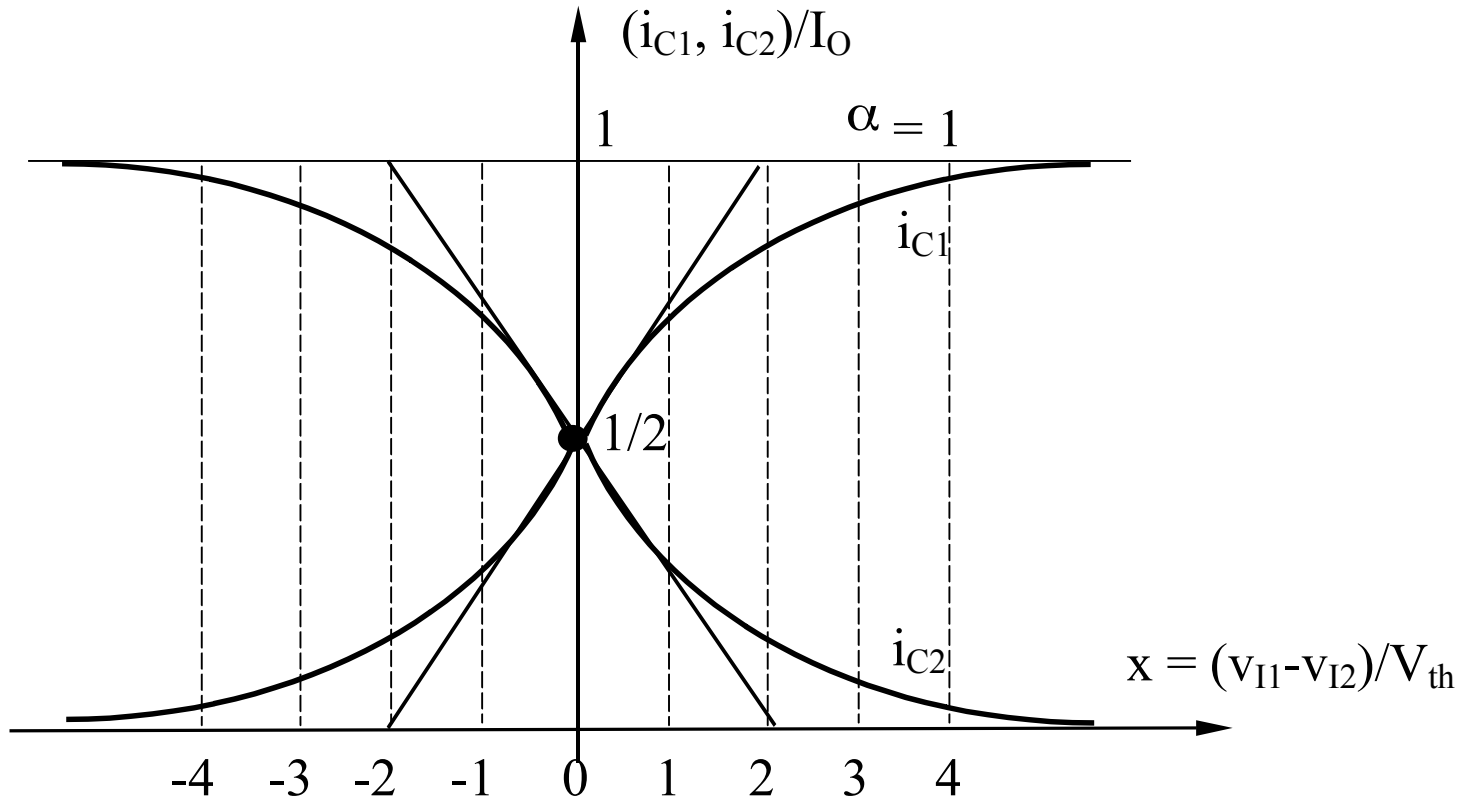

Tensiunea de iesire simetrica are expresia:

$$v_O = v_{O1} - v_{O2} = (i_{C2} - i_{C1})R_C = \left( -\frac{x}{2} + \frac{x^3}{24} - \dots \right) I_O R_C$$

Caracteristica statica  $v_{O1} - v_{O2} = f [(v_{I1} - v_{I2})/V_{th}]$  a amplificatorului diferential bipolar

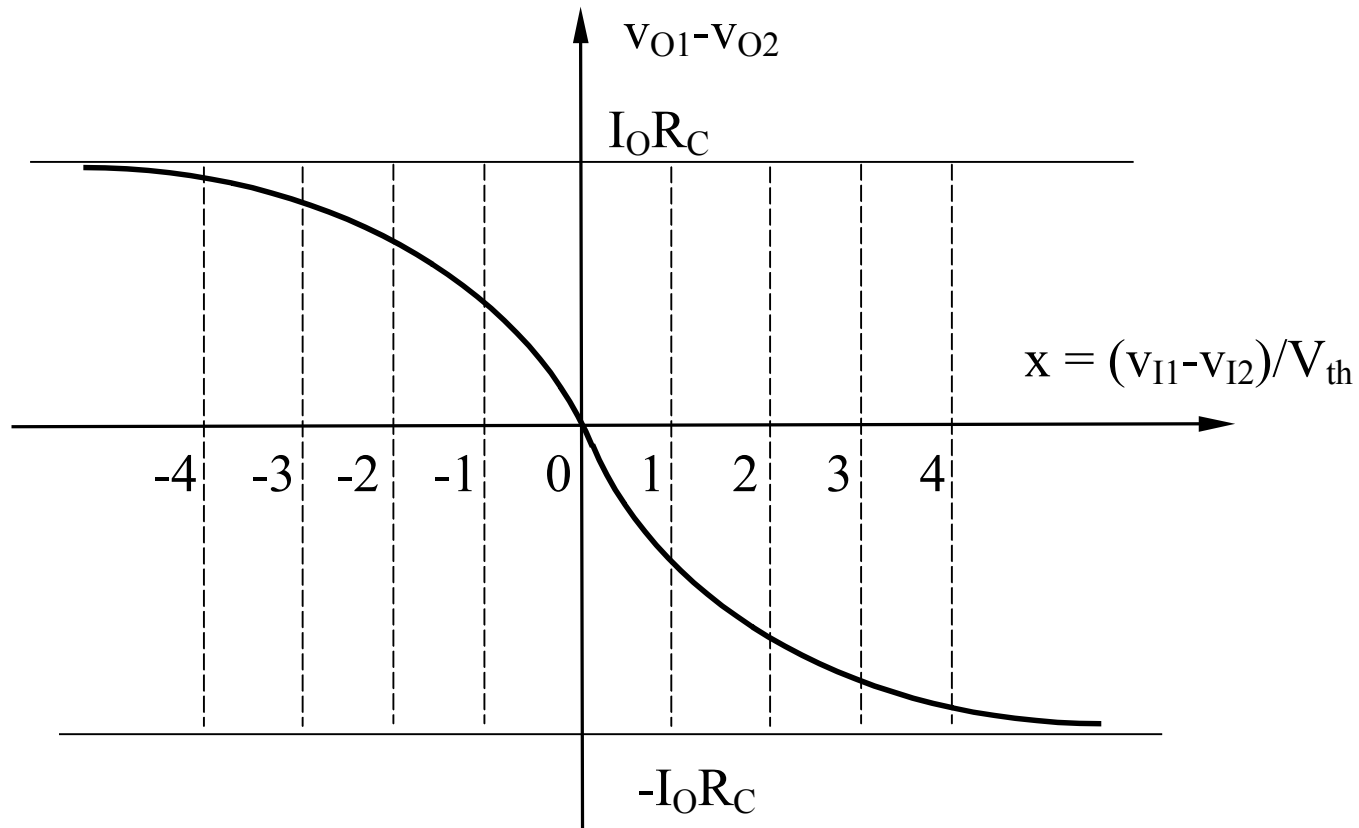

Cresterea domeniului maxim al tensiunii de intrare (pentru o functionare liniara) – prin introducerea unor rezistente serie in emitor

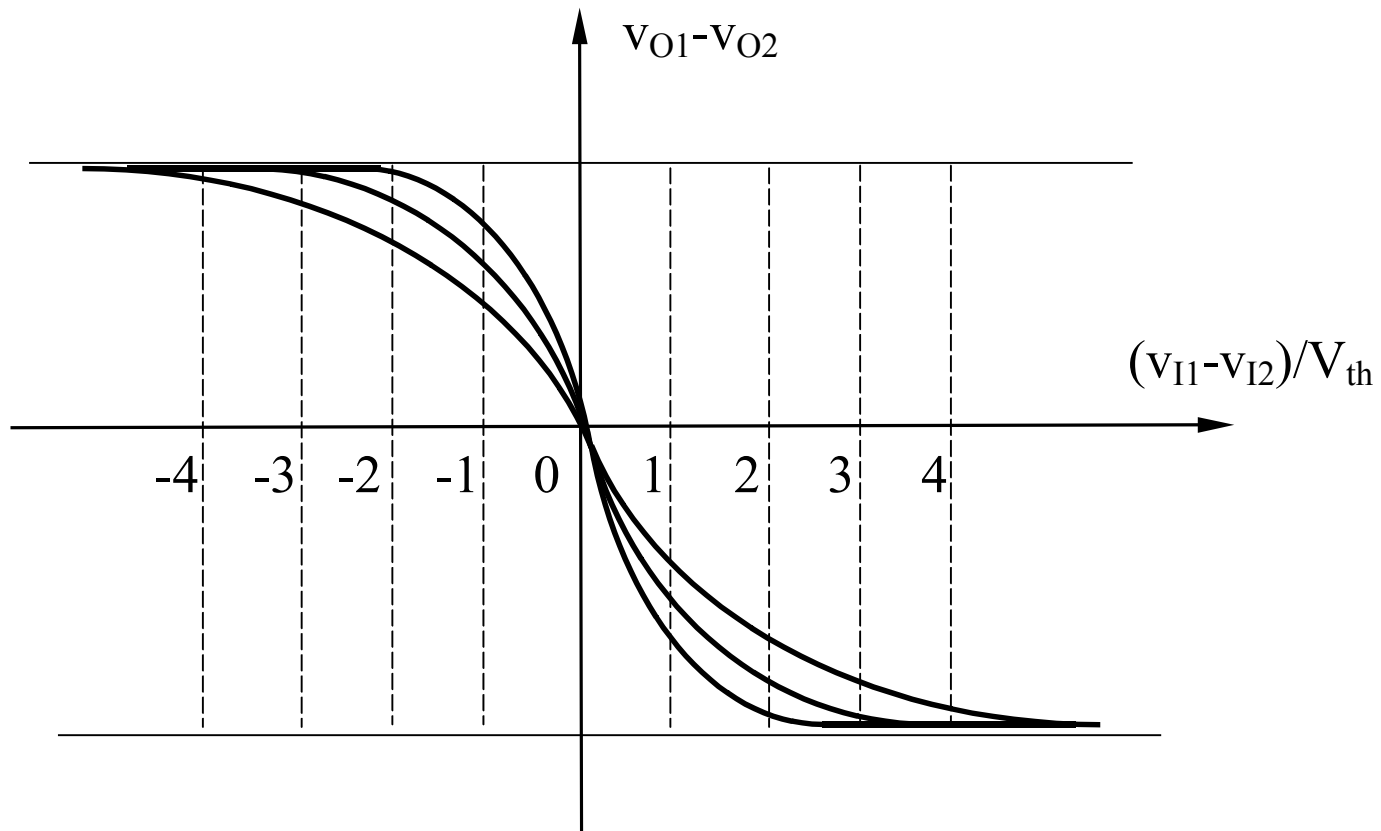



# Analiza de semnal mic

## Determinarea amplificarii: metoda semicircuitului

Mod diferential (  $v_{id} \neq 0$ ,  $v_{ic} = 0 \Rightarrow v_{i1} = v_{id}/2$ ,  $v_{i2} = -v_{id}/2$  )

S-a introdus rezistenta de sarcina suplimentara (  $R_1$  ).

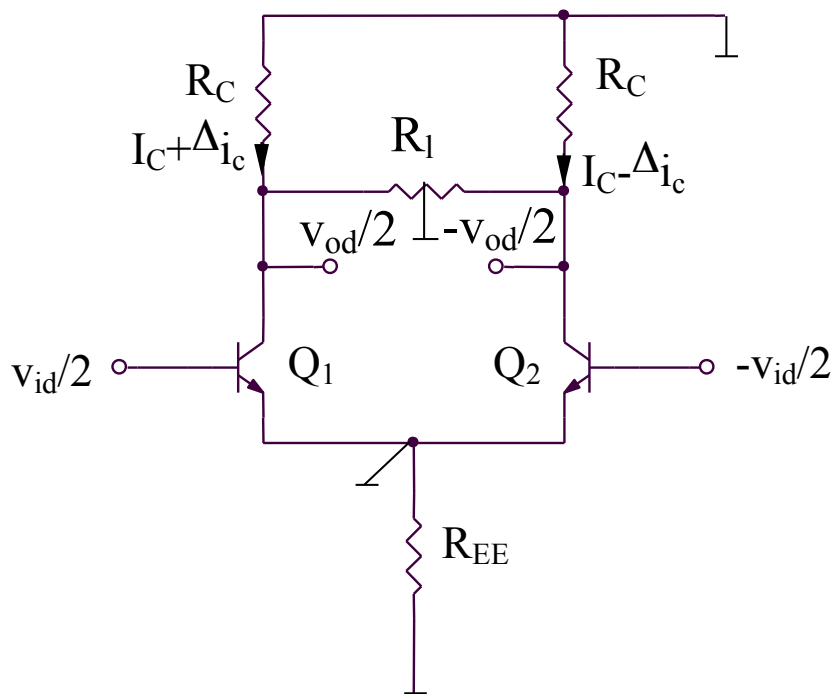

(a)

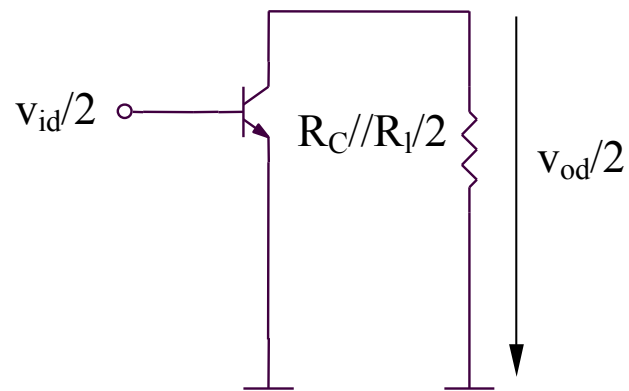

(b)

Amplificarea semicircuitului:

$$A = \frac{v_{od} / 2}{v_{id} / 2} = \frac{v_{od}}{v_{id}} = -g_m \left( R_C // \frac{R_l}{2} \right)$$

Amplificarea de mod diferential:

- iesire diferentiala (simetrica):

$$A_{dd} = \frac{v_{od} / 2 - (-v_{od} / 2)}{v_{id} / 2 - (-v_{id} / 2)} = \frac{v_{od}}{v_{id}} = A = -g_m \left( R_C // \frac{R_l}{2} \right)$$

- iesire simpla (asimetrica)

$$A_{dd} = \frac{v_{od} / 2}{v_{id} / 2 - (-v_{id} / 2)} = \frac{1}{2} \frac{v_{od}}{v_{id}} = \frac{A}{2} = -\frac{1}{2} g_m \left( R_C // \frac{R_l}{2} \right)$$

Rezistenta de intrare de mod diferential:

$$R_{id} = 2r_\pi$$

**Mod comun** ( $v_{ic} \neq 0, v_{id} = 0 \Rightarrow v_{i1} = v_{ic}, v_{i2} = -v_{ic}$ )

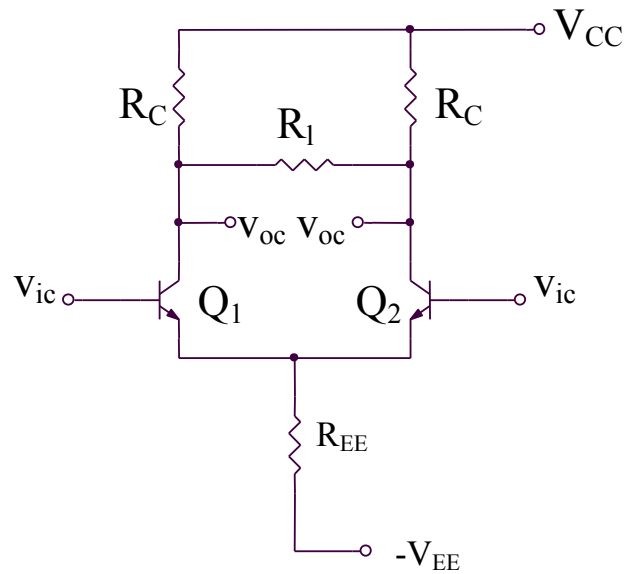

(a)

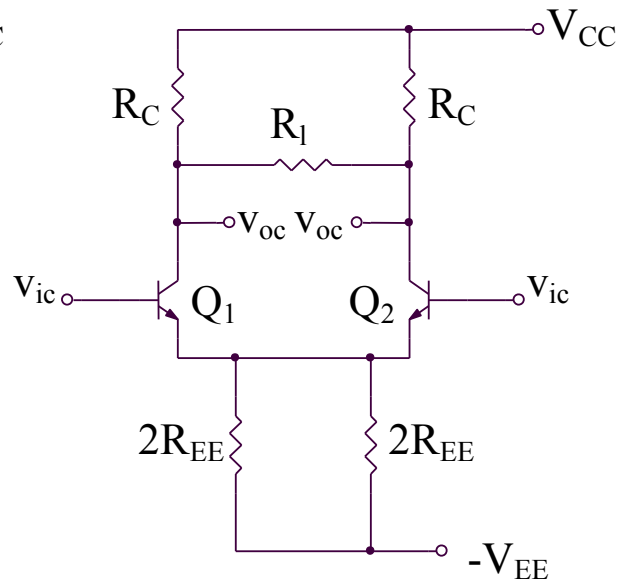

(b)

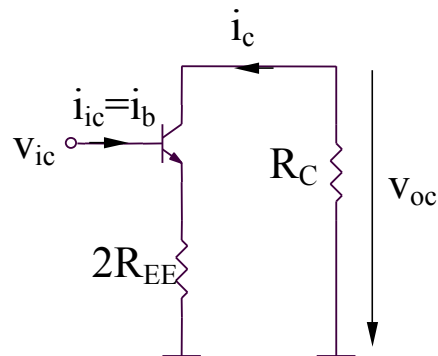

(c)

Amplificarea de mod comun:

$$A_{cc} = \frac{v_{oc}}{v_{ic}} = - \frac{\beta_0 R_C}{r_\pi + (\beta_0 + 1)2R_{EE}} \cong - \frac{R_C}{2R_{EE}}$$

Rezistenta de intrare de mod comun:

$$R_{ic} = \frac{v_{ic}}{i_{ic}} = r_\pi + (\beta_0 + 1)2R_{EE}$$

**Raportul de rejectie a modului comun (CMRR)** - caracterizeaza capacitatea amplificatorului diferential de a amplifica semnalele de mod diferential si de a rejecta semnalele de mod comun.

- pentru iesire diferentiala ( $v_{od} = 0$  pentru  $v_{ic}$ , deci  $A_{cm} = A_{cd} = 0$ ), deci:

$$CMRR = \left| \frac{A_{dm}}{A_{cm}} \right| = \left| \frac{A_{dd}}{A_{cd}} \right| = \left| \frac{-g_m R_C}{0} \right| = \infty$$

- pentru iesire simpla ( $v_o = v_{o1}$  sau  $v_{o2}$ )

$$CMRR = \left| \frac{A_{dm}}{A_{cm}} \right| = \left| \frac{A_{dd} / 2}{A_{cc}} \right| = \left| \frac{-g_m R_C / 2}{-R_C / 2R_{EE}} \right| = g_m R_{EE}$$

Pentru cresterea CMRR, este necesara inlocuirea rezistentei  $R_{EE}$  cu o sursa de curent.

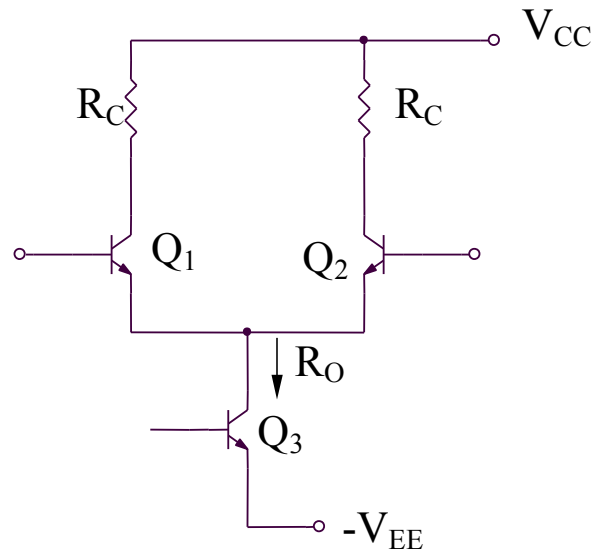

$R_O$  reprezinta rezistenta de iesire a sursei de curent.

$$A_{cc} = -\frac{R_C}{2R_O}$$

# Determinarea domeniului maxim al tensiunii de intrare de mod comun

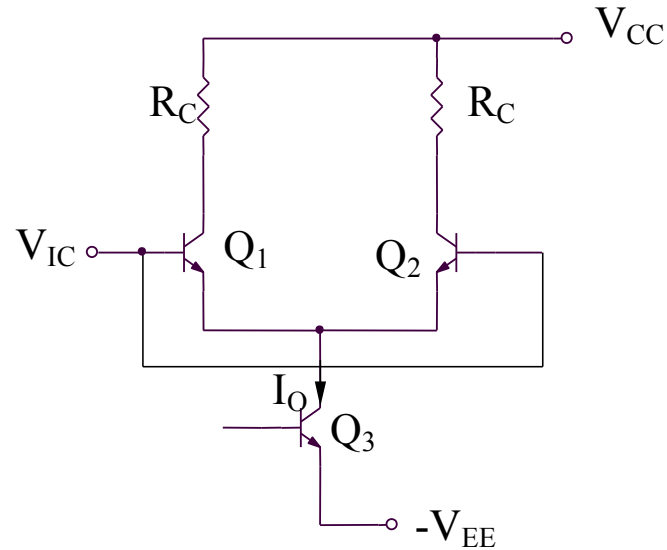

$$V_{IC}^{max} = V_{CC} - R_C \frac{I_O}{2} - V_{CE1sat} + V_{BE1}$$

$$V_{IC}^{min} = -V_{EE} + V_{CE3sat} + V_{BE1}$$

**SIMULARI pentru amplificatorul diferential bipolar**  
**Analiza de mod diferential si semnal mare**

# SIMULARI pentru amplificatorul diferential bipolar

## Analiza de mod diferential si semnal mare

### SIM 4.6: $V_O$ (V2)

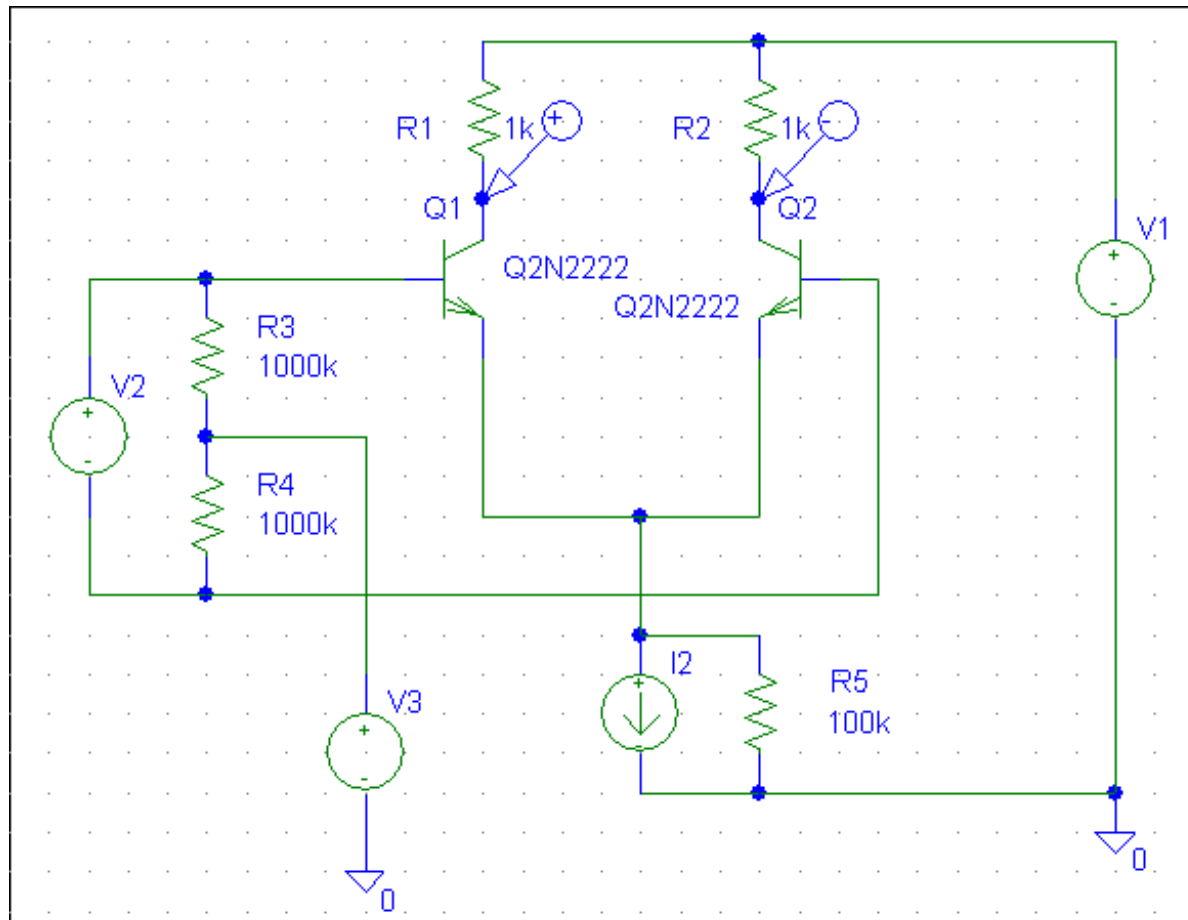



# SIMULARI pentru amplificatorul diferential bipolar

## Analiza de mod diferential si semnal mare

SIM 4.7:  $i_{C1}$ ,  $i_{C2}$  (V2)

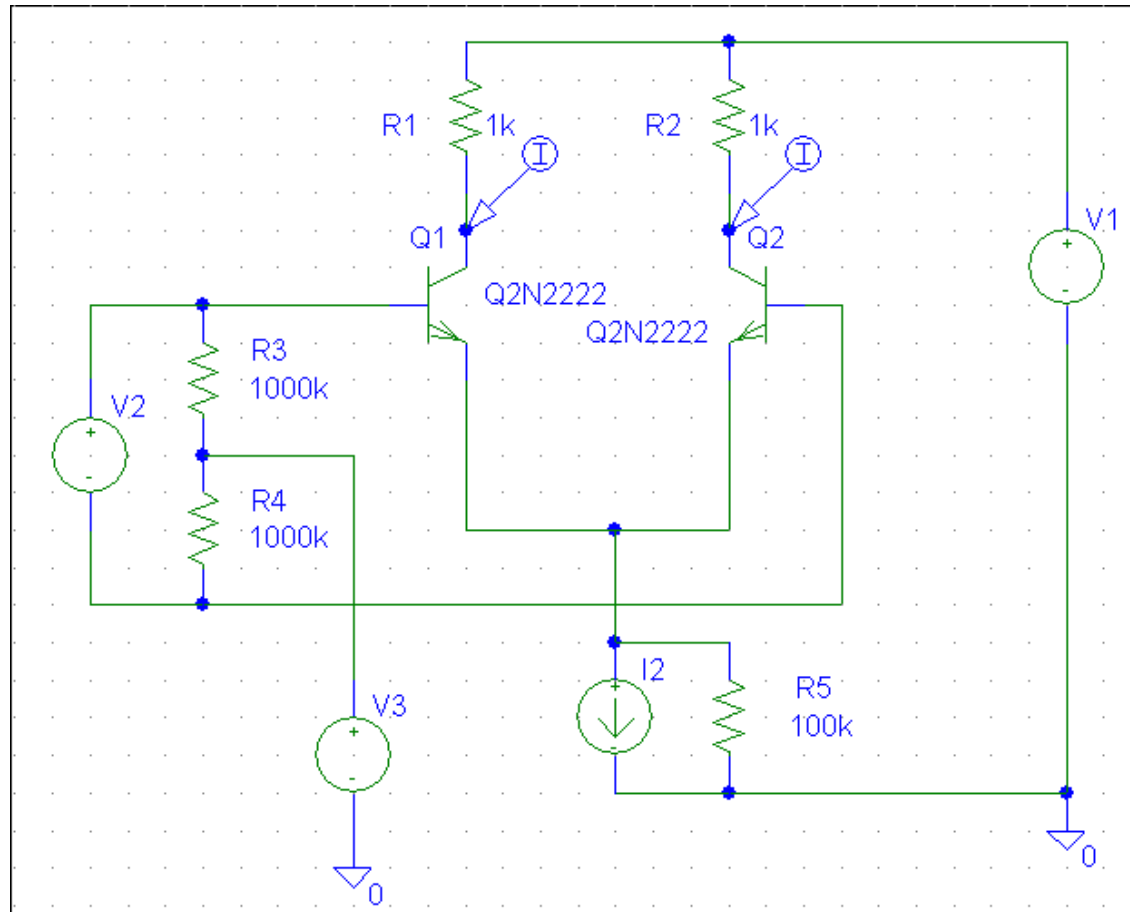

# SIMULARI pentru amplificatorul diferential bipolar

## Analiza de mod diferential si semnal mare

### SIM 4.8: $V_O$ (V2), I2 - parametru

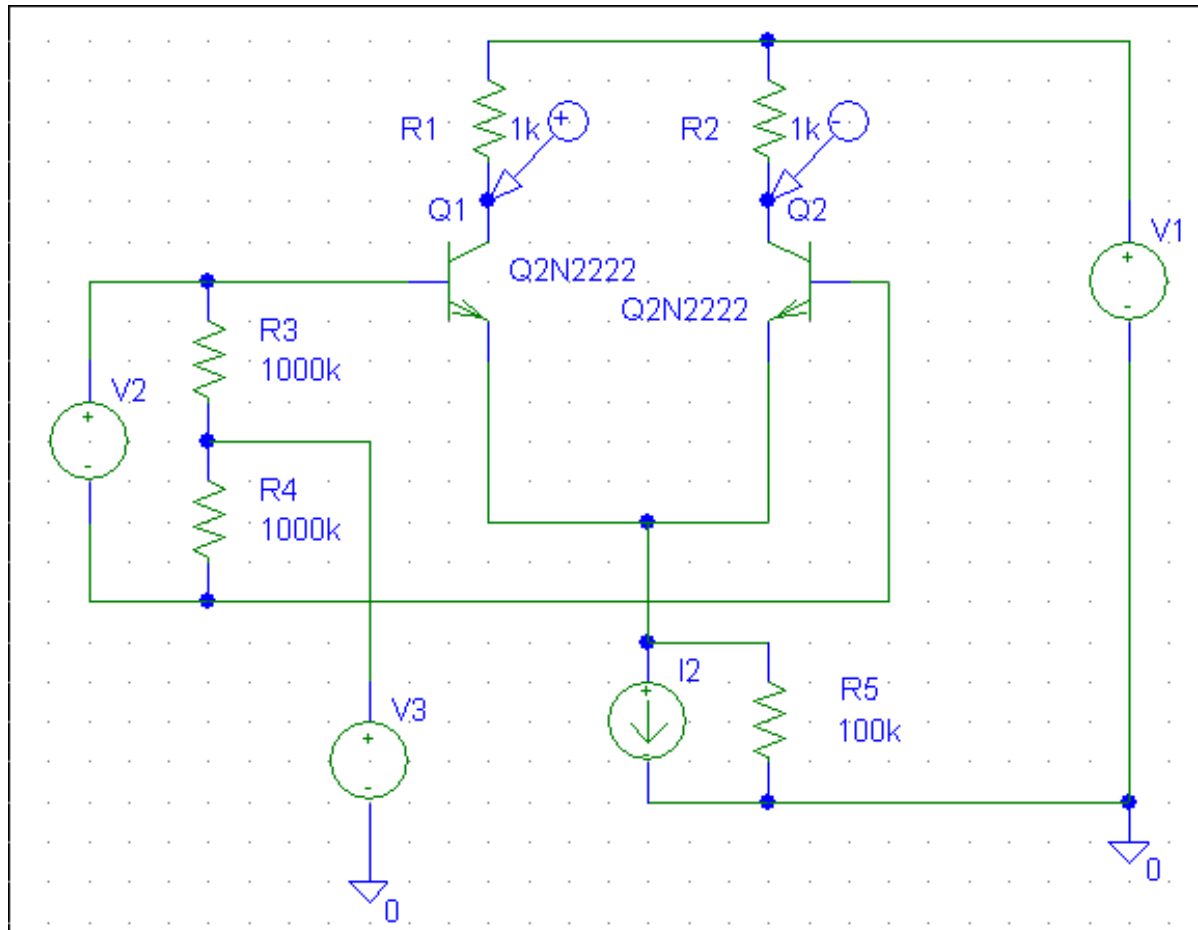

# SIMULARI pentru amplificatorul diferential bipolar

## Analiza de mod diferential si semnal mare

### SIM 4.9: $i_{C1}$ , $i_{C2}$ (V2), I2 - parametru

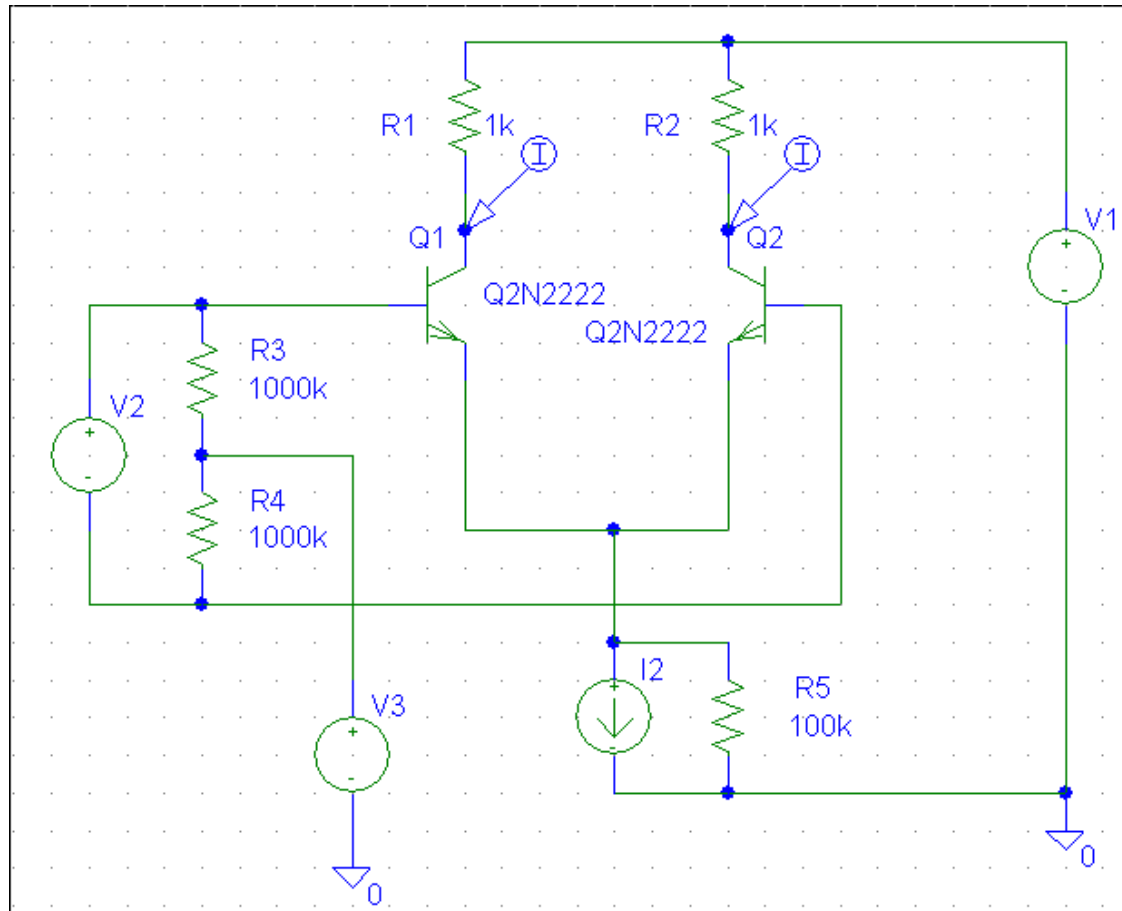

**SIMULARI pentru amplificatorul diferential bipolar**  
**Analiza de mod comun si semnal mare**

# SIMULARI pentru amplificatorul diferential bipolar

## Analiza de mod comun si semnal mare

SIM 4.10:  $V_{C1}$  (V2)

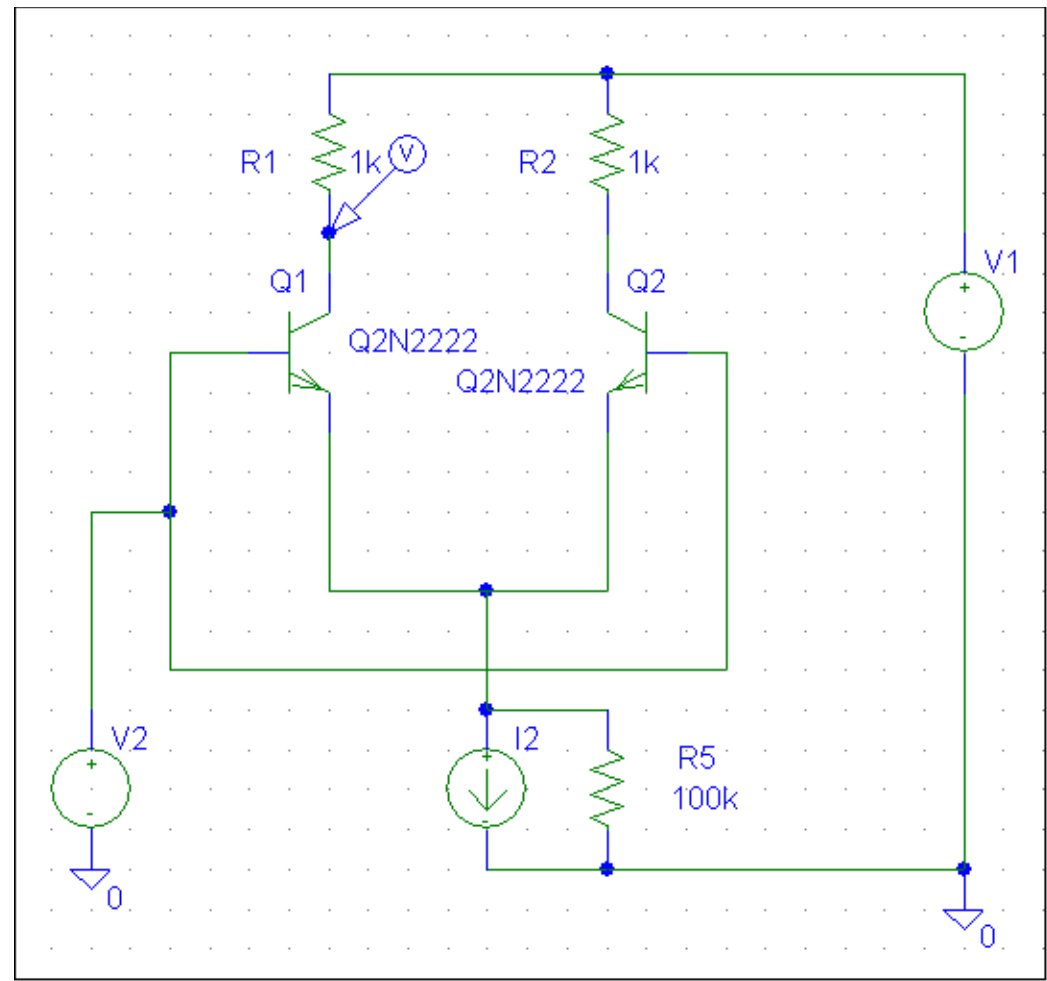

# SIMULARI pentru amplificatorul diferential bipolar

## Analiza de mod comun si semnal mare

### SIM 4.11: $V_{C1}$ (V2), $V_{A5}$ - parametru

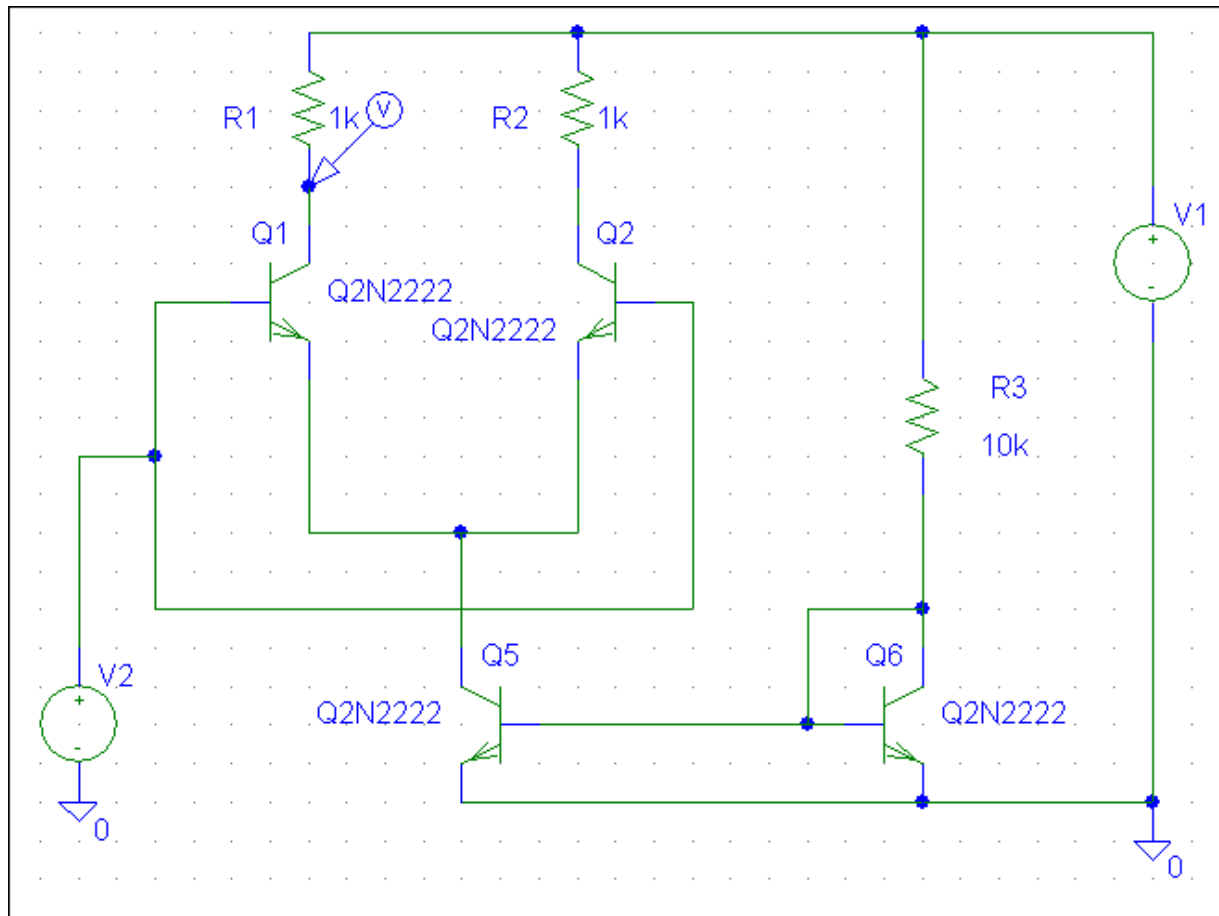

## Tensiunea de offset (decalaj) de intrare

Daca cele doua tranzistoare nu sunt identice, este necesara aplicarea unei tensiuni de intrare nenule (numita tensiune de offset de intrare) in vederea anularii tensiunii de iesire.

$$v_{IO} = v_{BE1} - v_{BE2} = V_{th} \ln\left(\frac{i_{C1} I_{S2}}{i_{C2} I_{S1}}\right)$$

Deoarece:

$$i_{C1} R_{C1} = i_{C2} R_{C2}$$

rezulta:

$$v_{IO} = V_{th} \ln\left(\frac{R_{C2} I_{S2}}{R_{C1} I_{S1}}\right)$$

Se definesc parametrii ce descriu asimetriile astfel:

$$x = \frac{x_1 + x_2}{2}$$

$$\Delta x = x_1 - x_2$$

$$x_1 = x + \frac{\Delta x}{2}$$

$$x_2 = x - \frac{\Delta x}{2}$$

Rezulta:

$$v_{IO} = V_{th} \ln \left( \frac{R_C - \frac{\Delta R_C}{2} \quad I_S - \frac{\Delta I_S}{2}}{R_C + \frac{\Delta R_C}{2} \quad I_S + \frac{\Delta I_S}{2}} \right) = V_{th} \ln \left( \frac{1 - \frac{\Delta R_C}{2R_C} \quad 1 - \frac{\Delta I_S}{2I_S}}{1 + \frac{\Delta R_C}{2R_C} \quad 1 - \frac{\Delta I_S}{2I_S}} \right)$$

Pentru:

$$\Delta R_C \ll R_C \text{ si } \Delta I_S \ll I_S$$

$$x = \Delta R_C / 2R_C \text{ sau } x = \Delta I_S / 2I_S$$

se poate utiliza aproximarea:

$$\frac{1-x}{1+x} \cong (1-x)(1-x) \cong 1-2x$$

Deci:

$$v_{IO} = V_{th} \ln \left[ \left( 1 - \frac{\Delta R_C}{R_C} \right) \left( 1 - \frac{\Delta I_S}{I_S} \right) \right] \cong -V_{th} \left( \frac{\Delta R_C}{R_C} + \frac{\Delta I_S}{I_S} \right)$$

deoarece:

$$\ln(1+x) \cong x, \text{ pentru } x \ll 1$$

Exemplu:

$$\frac{\Delta R_C}{R_C} = 0,01; \quad \frac{\Delta I_S}{I_S} = 0,05 \Rightarrow v_{IO} = 1,5mV$$



## 4.4.2. Amplificatorul diferential bipolar elementar cu sarcina activa

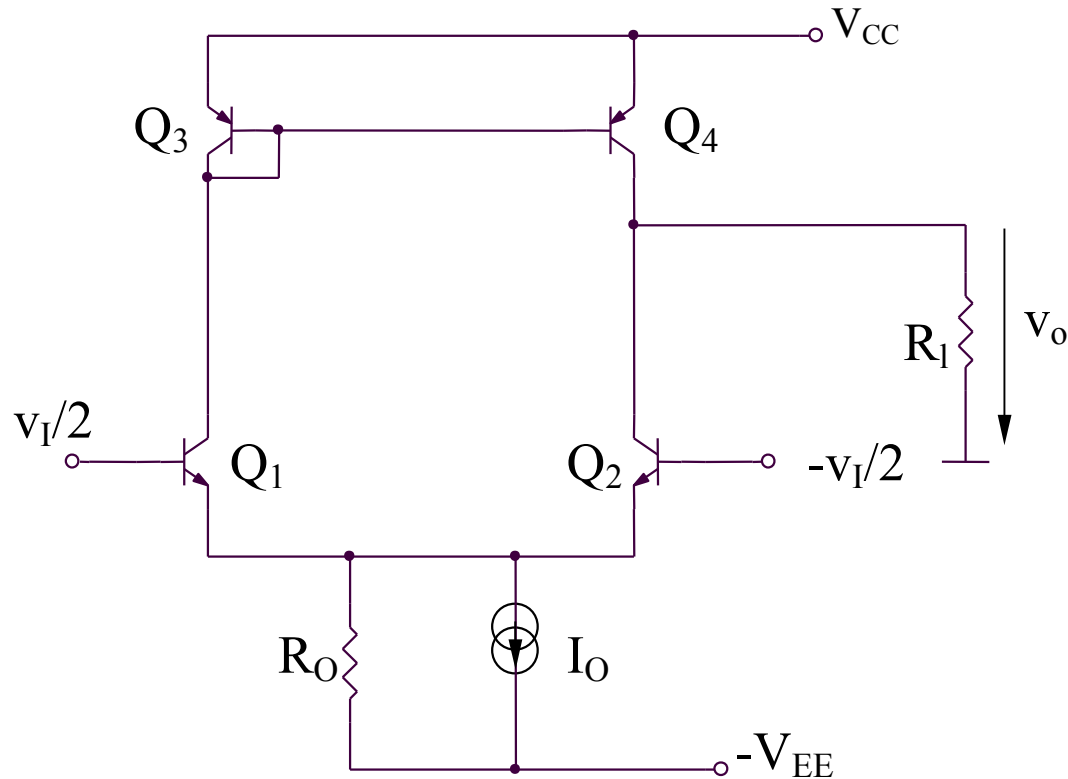

$$v_O = \left( g_{m1} \frac{v_I}{2} + g_{m2} \frac{v_I}{2} \right) (R_l \parallel r_{o2} \parallel r_{o4}) = g_{m1} v_I (R_l \parallel r_{o2} \parallel r_{o4})$$

$$A_{dd} = g_{m1} (R_l \parallel r_{o2} \parallel r_{o4})$$

$$A_{dd} \Big|_{R_l \rightarrow \infty} = g_{m1} (r_{o2} \parallel r_{o4}) = \frac{g_{m1} r_{o2}}{2} = \frac{I_{C1}}{2} \frac{V_A}{I_{C1}} = \frac{V_A}{2V_{th}}$$

## **4.5. Amplificatorul diferential bipolar cascod**

## 4.5. Amplificatorul diferential bipolar cascod

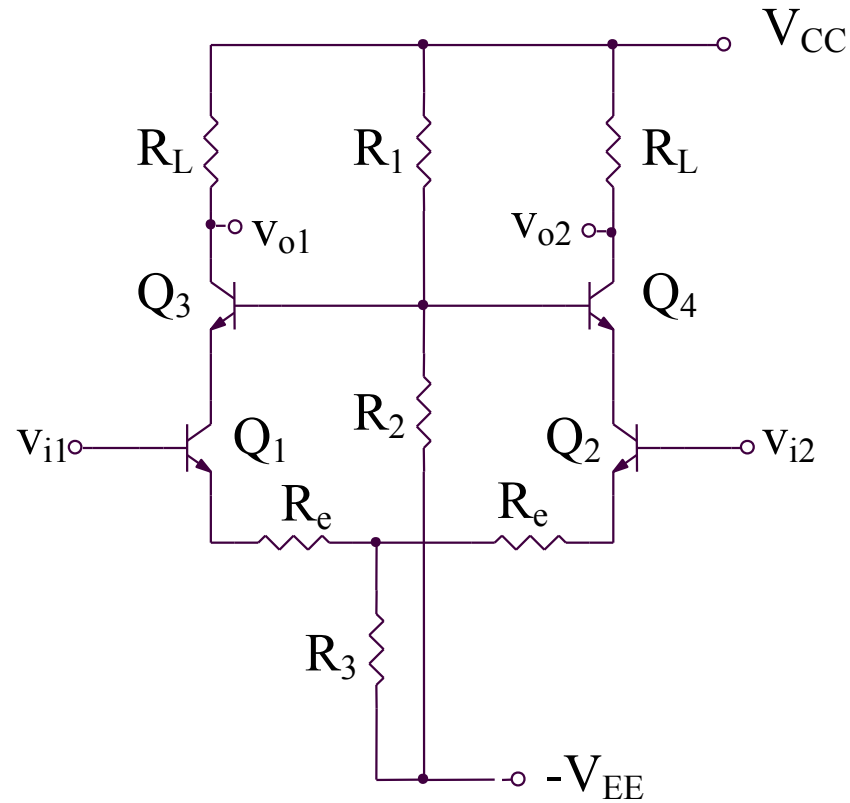

## Mod diferential

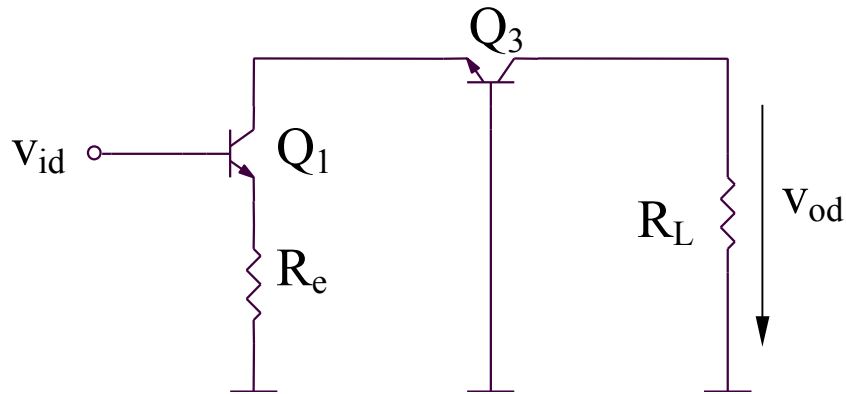

Semicircuitul de mod diferential

$$A_{dd} = - \frac{\beta R_L}{r_{\pi} + (\beta + 1) R_E}$$

## Mod comun

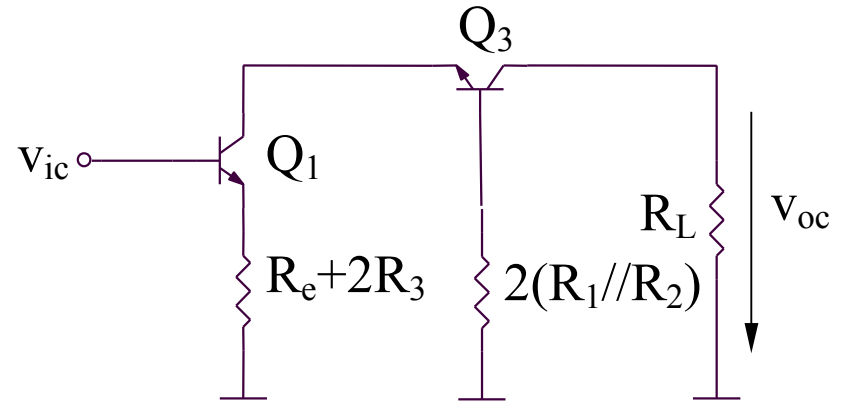

Semicircuitul de mod comun

$$A_{cc} = - \frac{\beta R_L}{r_{\pi} + (\beta + 1)(R_E + 2R_3)}$$

## **4.6. Amplificator diferential polarizat cu o sursa dubla de curent**

## 4.6. Amplificator diferential polarizat cu o sursa dubla de curent

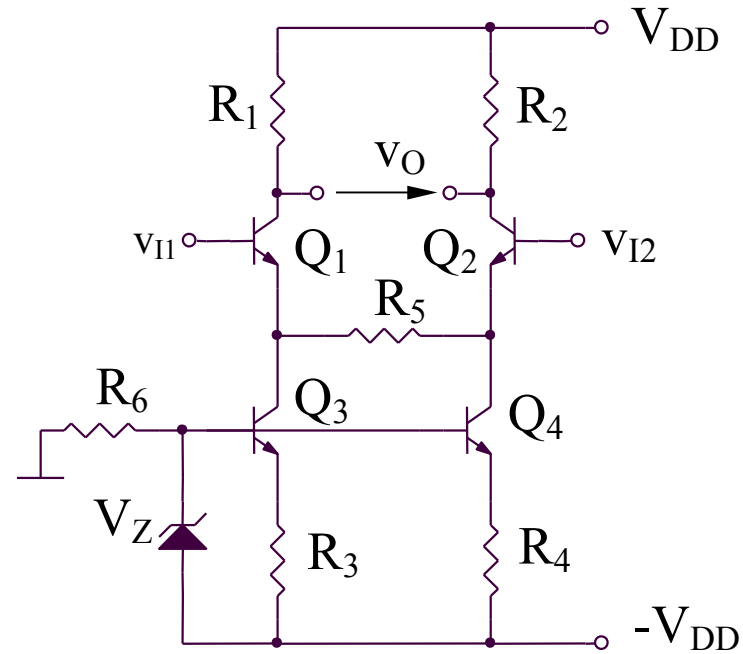

## Mod diferential

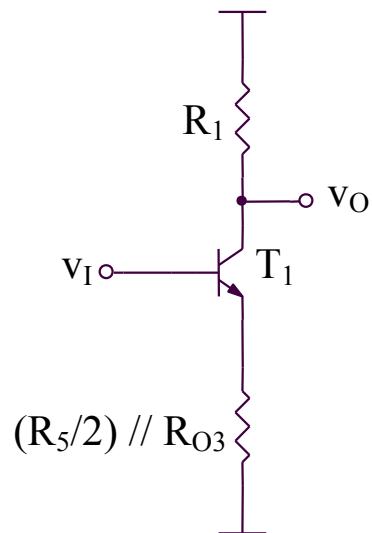

Semicircuitul de mod diferential

$$A_{dd} = - \frac{\beta R_1}{r_{\pi 1} + (\beta + 1) \left( \frac{R_5}{2} \parallel R_{O3} \right)}$$

## Mod comun

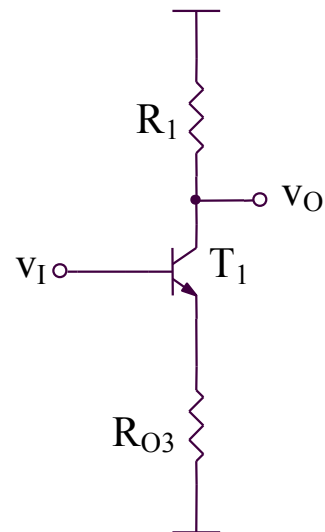

Semicircuitul de mod comun

$$A_{cc} = - \frac{\beta R_1}{r_{\pi 1} + (\beta + 1) R_{O3}} \cong - \frac{R_1}{R_{O3}}$$

$$R_{O3} = r_{o3} \left( 1 + \frac{\beta R_3}{r_{\pi 3} + R_3 + R_6 \parallel r_Z} \right)$$

## **4.7. Structura cu 2 amplificatoare diferentiale**



## 4.7. Structura cu 2 amplificatoare diferentiale

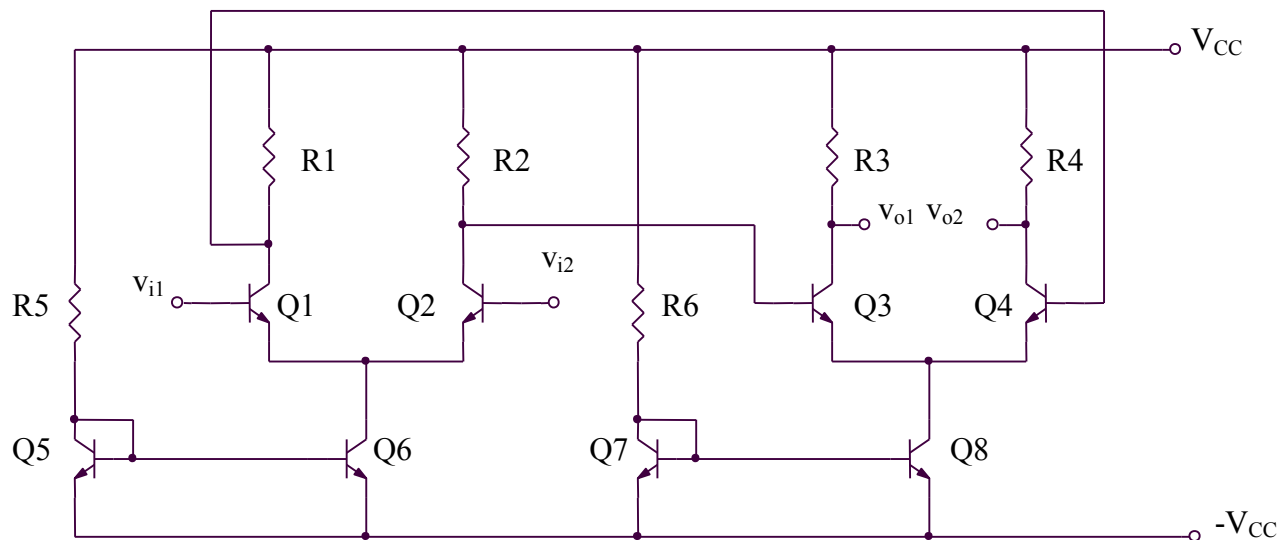

# Mod diferential

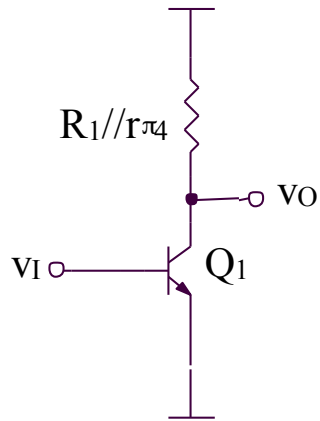

Semicircuitul de mod diferential (I)

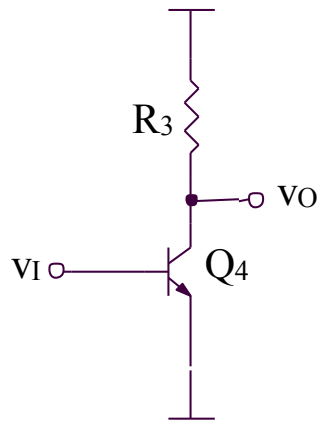

Semicircuitul de mod diferential (II)

# Mod comun

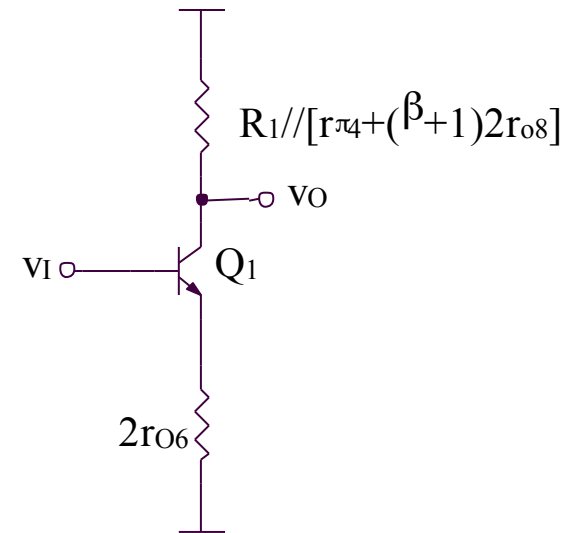

Semicircuitul de mod comun (I)

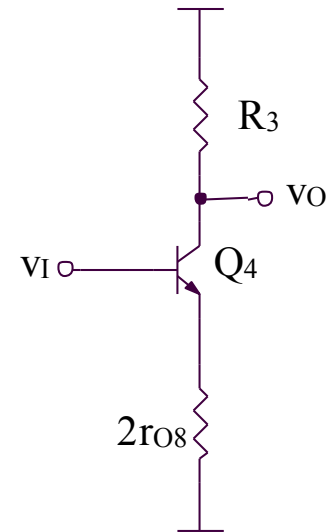

Semicircuitul de mod comun (II)

Amplificarea de mod diferential (I)

$$A_{dd1} = -g_{m1}(R_1 // r_{\pi4})$$

Amplificarea de mod diferential (II)

$$A_{dd2} = -g_{m4}R_3$$

Amplificarea de mod comun (I)

$$A_{cc1} = -\beta \frac{R_1 // [r_{\pi4} + (\beta + 1)2r_{o8}]}{r_{\pi1} + (\beta + 1)2r_{o6}}$$

Amplificarea de mod comun (II)

$$A_{cc2} = -\beta \frac{R_3}{r_{\pi1} + (\beta + 1)2r_{o8}}$$

## **4.8. Amplificator diferential CMOS** **cu caracteristica de transfer liniarizata**

## 4.8. Amplificator diferential CMOS cu caracteristica de transfer liniarizata

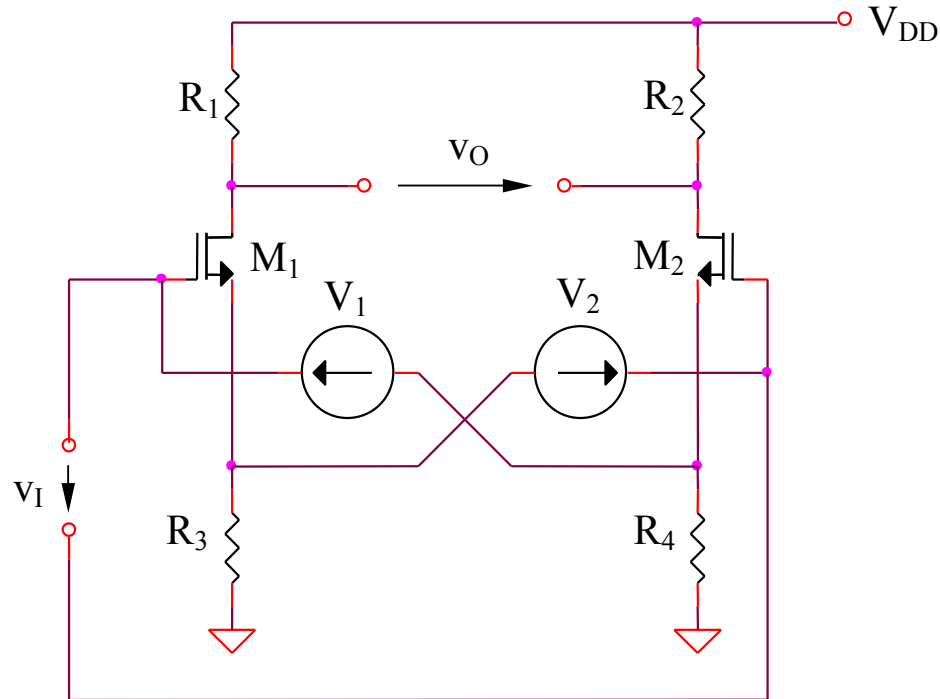

$$i_{D1} = \frac{K}{2} (v_{GS1} - V_T)^2 \qquad i_{D2} = \frac{K}{2} (v_{GS2} - V_T)^2$$

$$v_O = R_1 (i_{D2} - i_{D1}) = \frac{KR_1}{2} (v_{GS2} - v_{GS1})(v_{GS2} + v_{GS1} - 2V_T)$$

$$v_I = V_1 - v_{GS2} = v_{GS1} - V_2 \Rightarrow \begin{cases} v_{GS1} - v_{GS2} = 2v_I \\ v_{GS1} + v_{GS2} = 2V \end{cases} \Rightarrow$$

$$\Rightarrow \begin{cases} v_O = -2KR_1(V - V_T)v_I \\ A_{dd} = \frac{v_O}{v_I} = -2KR_1(V - V_T) \end{cases}$$

$$V_1 = V_2 = V$$

# Implementare posibila

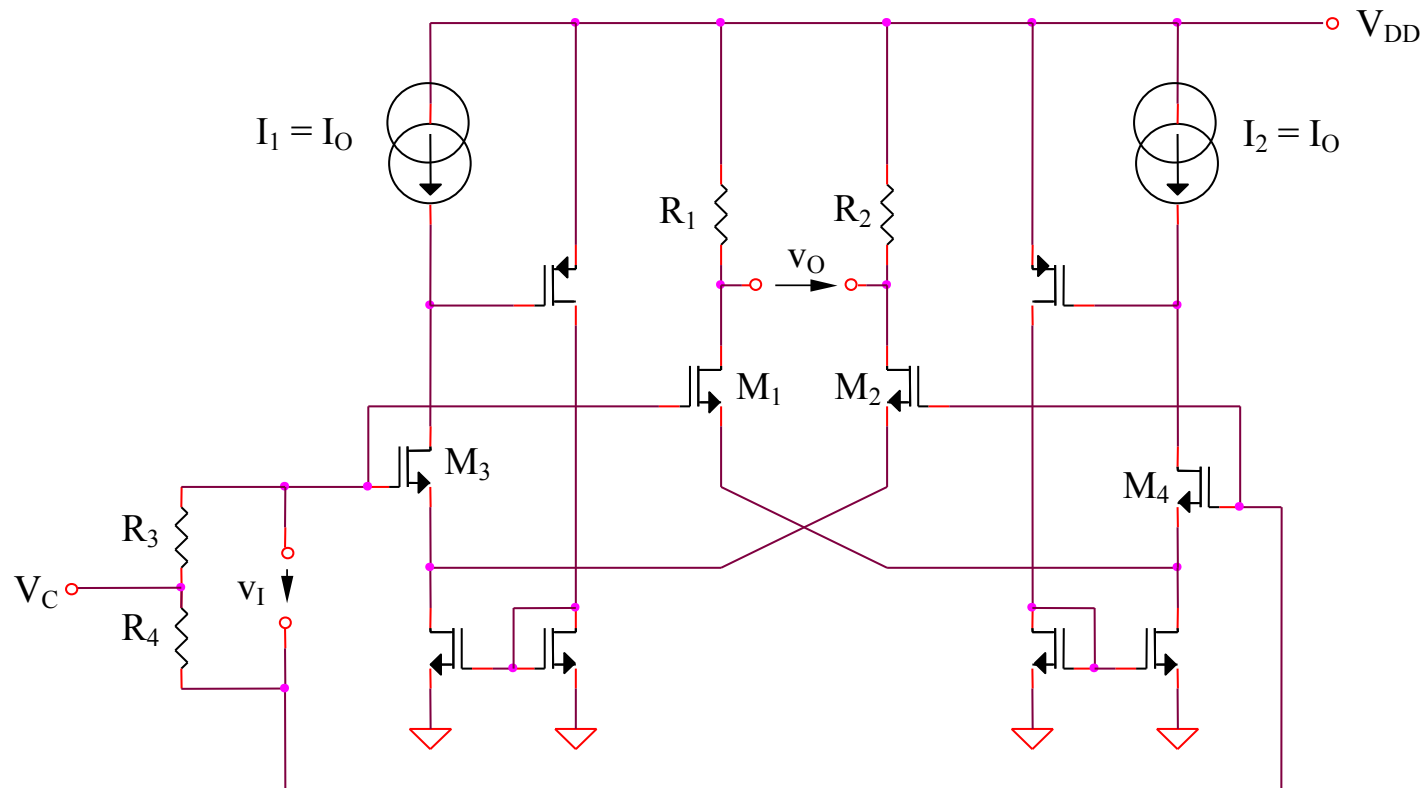

$$V_1 = V_2 = V_{GS3} = V_{GS4} = V_T + \sqrt{\frac{2I_O}{K}} \quad \Rightarrow \quad A_{dd} = -2R_1\sqrt{2KI_O}$$

## **4.9. Amplificatoare diferentiale CMOS de tip cascod**



## 4.9.1. Amplificator diferential CMOS de tip cascod intoarsa (1) (folded cascod)

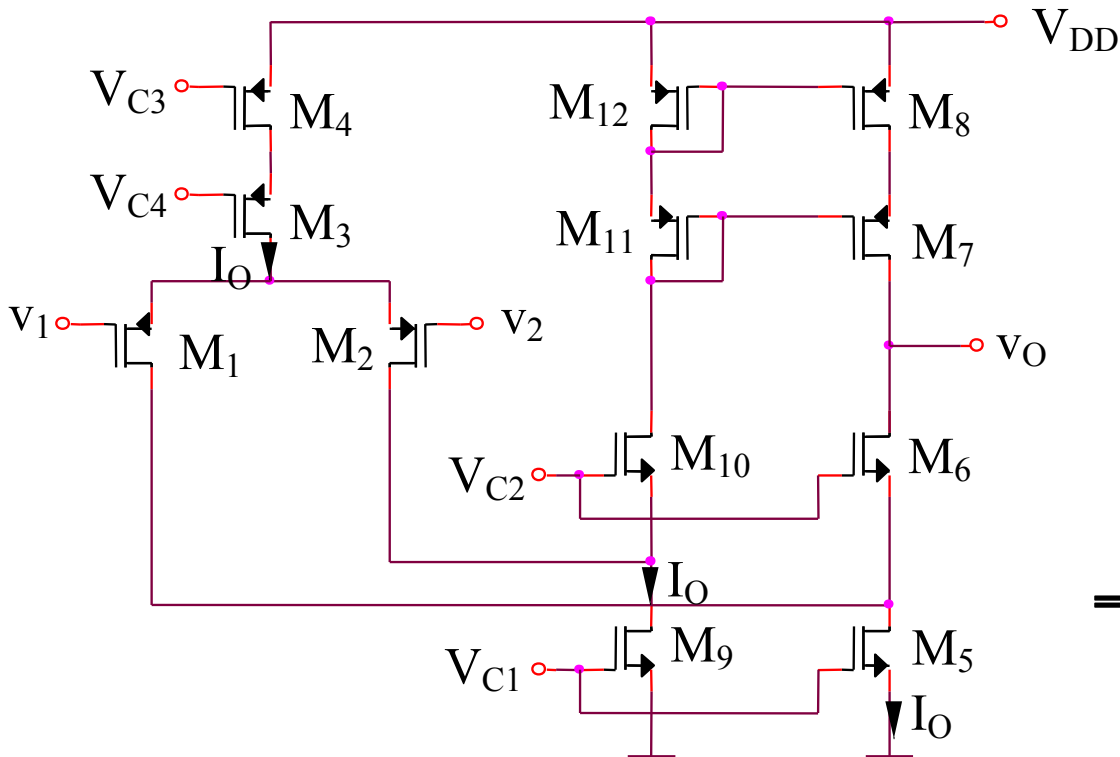

**Curentii in PSF:**

$$I_{D3} = I_{D4} = I_{D5} = I_{D9} = I_O$$

(fixati de  $V_{C1}, V_{C3}$ )

$$I_{D1} = I_{D2} = \frac{I_{D3}}{2} = \frac{I_O}{2}$$

$$I_{D6} = I_{D7} = I_{D8} = I_{D10} = \\ = I_{D11} = I_{D12} = I_{D9} - I_{D2} = \frac{I_O}{2}$$

**Curentul de iesire:**

$$i_O = i_{D7} - i_{D6} = i_{D10} - i_{D6} = (i_{D9} - i_{D2}) - (i_{D5} - i_{D1}) = i_{D1} - i_{D2} = g_{m1}(v_1 - v_2)$$

$$v_O = i_O R_O = g_{m1} R_O (v_1 - v_2) = g_{m1} (v_1 - v_2) [r_{ds7} g_{m7} r_{ds8} // r_{ds6} g_{m6} (r_{ds5} // r_{ds1})]$$

**Amplificarea:** 
$$A = \frac{v_O}{v_1 - v_2} = g_{m1} [g_{m7} r_{ds8}^2 // g_{m6} r_{ds6} (r_{ds5} // r_{ds1})]$$

## 4.9.2. Amplificator diferential CMOS de tip cascada intoarsa (2) (folded cascod)

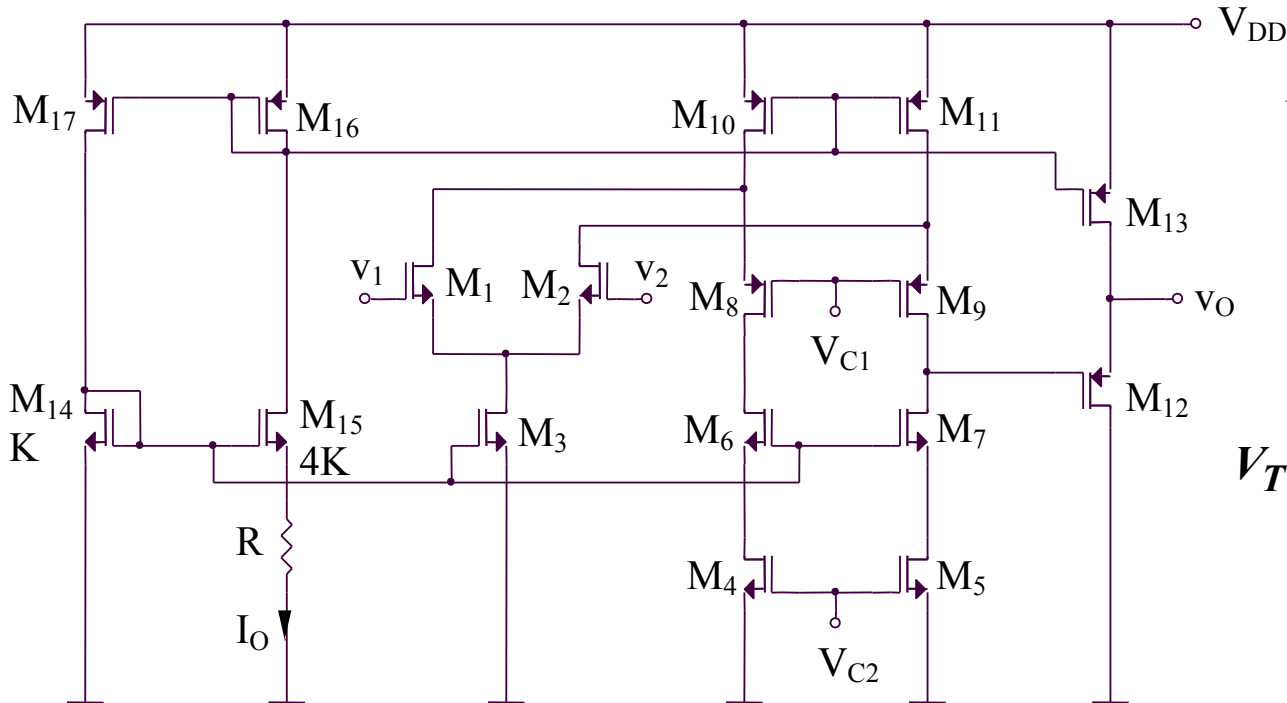

**Curentii in PSF:**

$$V_{C2} \text{ fixeaza } I_{C4} = I_{C5} = I_O/2$$

$$V_{GS14} = V_{GS15} + I_O R$$

$$V_T + \sqrt{\frac{2I_O}{K}} = V_T + \sqrt{\frac{2I_O}{4K}} + I_O R$$

$$I_O = \frac{1}{2KR^2}$$

$$I_{D1} = I_{D2} = I_{D4} = \dots = I_{D9} = \frac{I_O}{2}$$

$$I_{D3} = I_O = I_{D10} = \dots = I_{D17}$$

$$I_{D4} = \frac{I_O}{2} = \frac{1}{4KR^2} = \frac{K}{2} (V_{C2} - V_T)^2$$

## 4.9.2. Amplificator diferential MOS de tip cascoda intoarsa (2) (folded cascod) - continuare

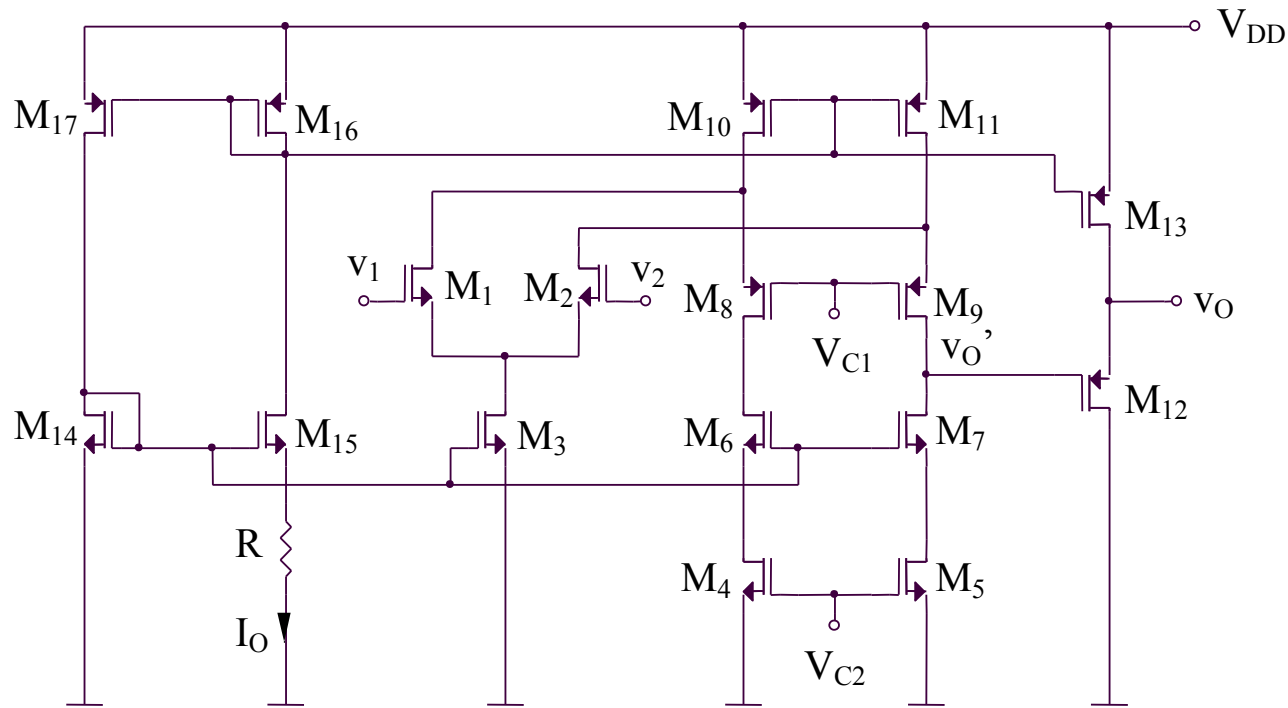

Curentul de iesire pentru calculul  $v_O'$  :

$$i_{O'} = i_{D9} - i_{D7} = i_{D9} - i_{D8} = (i_{D11} - i_{D2}) - (i_{D10} - i_{D1}) = i_{D1} - i_{D2} = g_{m1}(v_1 - v_2)$$

$$v_{O'} = i_{O'} R_{O'} = g_{m1} R_{O'} (v_1 - v_2)$$

Amplificarea:  $A = g_{m1} R_{O'} = g_{m1} \left\{ r_{ds7} g_{m7} r_{ds5} \parallel \left[ r_{ds9} g_{m9} (r_{ds11} \parallel r_{ds2}) \right] \right\}$

### 4.9.3. Amplificator diferential MOS de tip cascada intoarsa (3) (folded cascod)

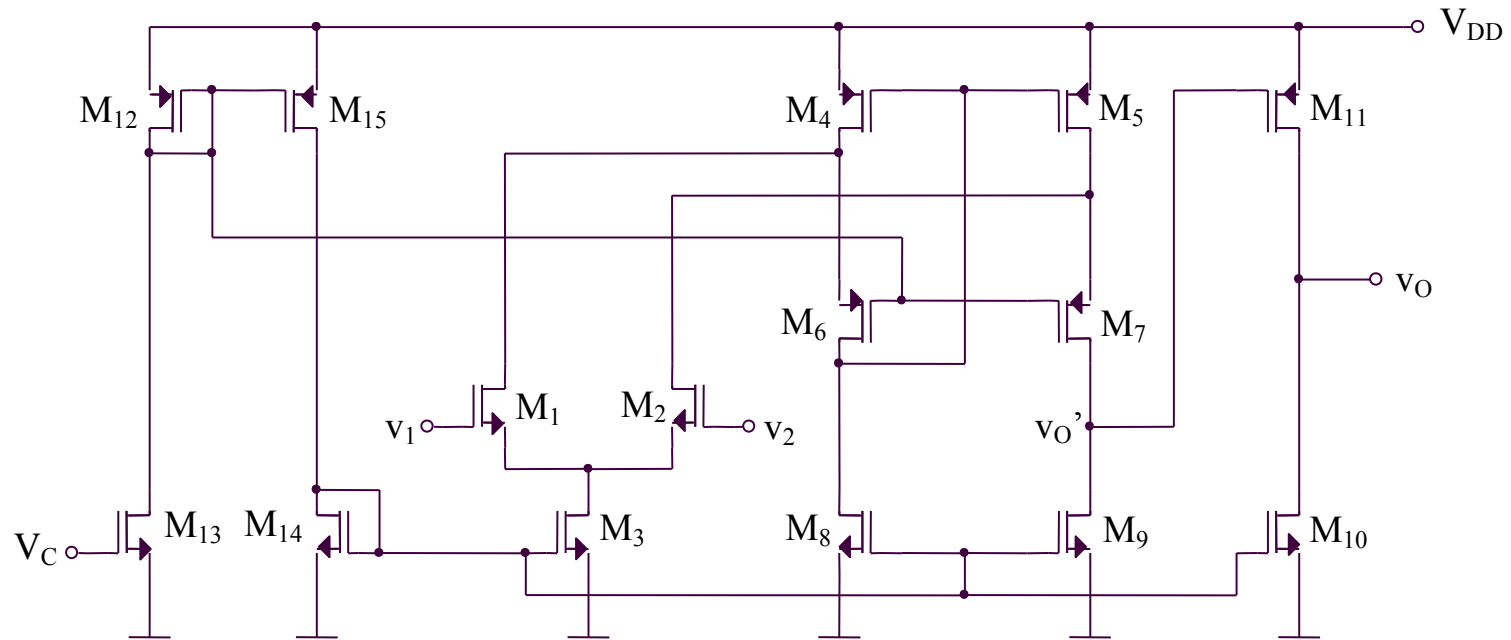

**Curentul de iesire pentru calculul  $v_O'$  :**

$$i_{O'} = i_{D7} - i_{D9} = (i_{D5} - i_{D2}) - (i_{D4} - i_{D1}) = i_{D1} - i_{D2} = g_{m1}R_{O'}(v_1 - v_2)$$

**Amplificarea:**

$$A_{dd1} = g_{m1}R_{O'} = g_{m1} \{ r_{ds9} // r_{ds7} [1 + g_{m7}(r_{ds2} // r_{ds5})] \} \cong g_{m1}r_{ds9}$$

$$A_{dd2} = -g_{m11}(r_{ds10} // r_{ds11})$$

$$A = A_{dd1}A_{dd2}$$